

STI Series
Stopper II



Description

The Stopper II is a unique and patented device that has been helping stop false fire alarms around the world for more than 20 years, without restricting legitimate alarms. It offers excellent protection against physical damage (both accidental and intentional), dust and grime as well as severe environments inside and out. It is ideal for schools, colleges, hospitals, nursing homes, stores, hotels and public buildings of almost every kind where there is a threat of false fire alarms.

The Stopper II consists of a clear, tamperproof, super tough polycarbonate shield and frame that fits over manual pull stations. When lifted to gain access to the actual alarm, it sounds a piercing self-contained 95 dB or 105 dB warning horn (at one foot). Immediate attention is drawn to the area and a prankster will either run or be caught. The cover is connected to the frame by a cable. When the cover is lifted, it drops off of the frame and a horn will sound (models with horn). Horn will sound until the cover is snapped back onto the frame or for the life of the battery.

Features

- Proven effective for more than 20 years in helping stop false fire alarms without restricting legitimate alarms
- Lifetime guarantee against breakage of polycarbonate housing in normal use (one year on electronic components)
- Can be used as a guard against physical damage to a manual pull station, with or without the optional warning horn
- Cover is UV-stabilized against sun deterioration
- Optional horn has choice of 95 dB or 105 dB at one foot
- Standard red units have “In Case of Fire...” label unless specified no label or custom label (charge for custom label)
- Horn housing available in red, blue, green or yellow with optional custom labeling
- When covering a pull station outside, UL requires stations to be listed for outdoor use
- UL Listed to U.S. and Canadian safety standards (also for custom labeling)
- Larger sizes and surface mounted pull stations accommodated with STI-3100 conduit spacer
- Polycarbonate tested for -40°F to 120°F (-40°C to 49°C)
- Weather models have closed cell gaskets
- Power source is 9 VDC alkaline battery included on standard Stopper II (remote powered unit is available)
- “RC” models include one form “C” dry relay contact and is capable of operating from 9-24 VDC remote power or internal 9 VDC battery power
- Not just for pull stations, this cover can also help protect other devices such as EPO’s, call boxes, telephones and emergency shutdowns just by changing the color and messaging
- With backplate and gaskets, UL Listed to NEMA 3R Standards (IP 14 Rating)



Dimension and Mounting Diagram

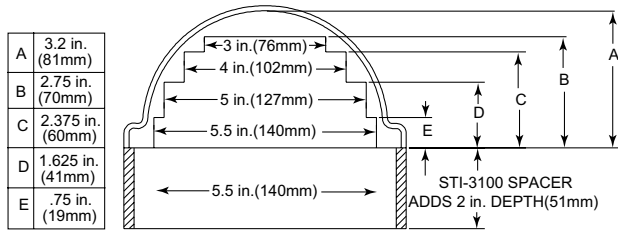

ALL MODELS END VIEW

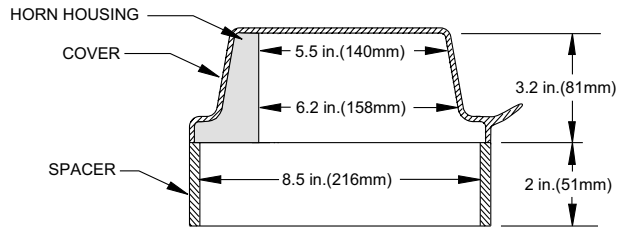

SIDE VIEW

MODELS WITH HORN (STI-1100 Series)

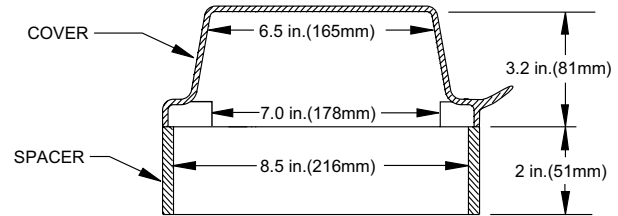

SIDE VIEW

MODELS WITHOUT HORN (STI-1200 Series)

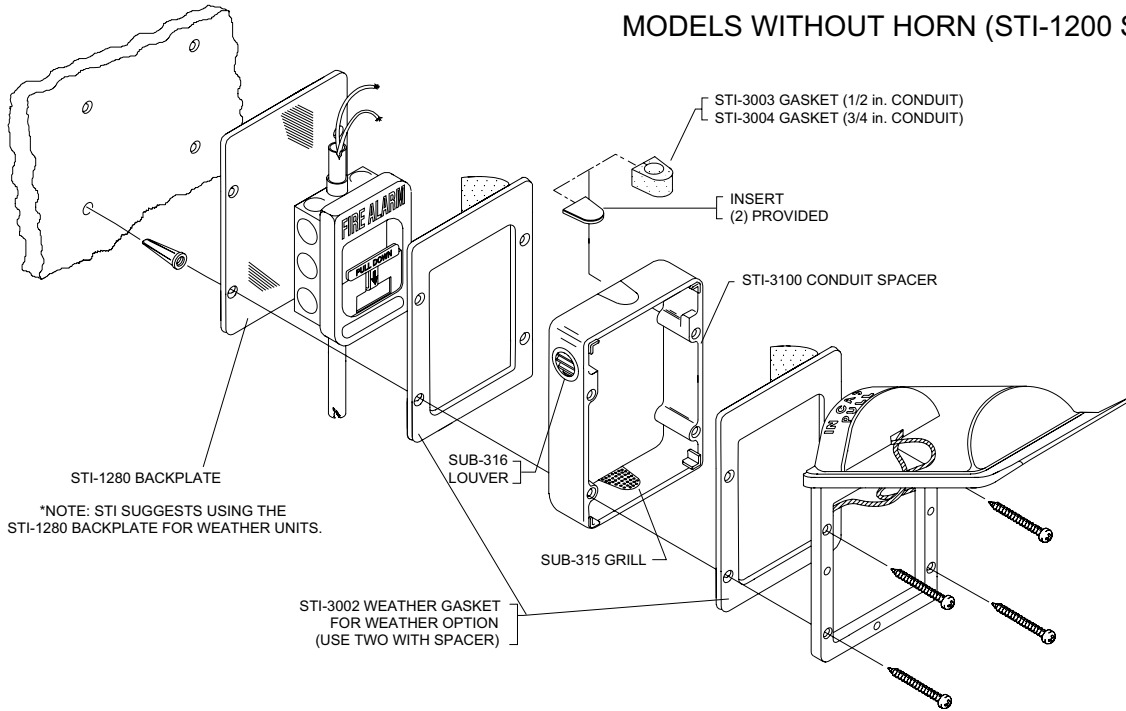

Ordering Information

Model	Description
Stopper II Models Indoor Use	
STI-1100	With horn for flush mount
STI-1100RC	With horn and relay flush mount
STI-1130	With horn and spacer
STI-1130RC	With horn and relay with spacer
STI-1200	Without horn flush mount
STI-1230	Without horn with spacer
Weather Stopper (Indoor/Outdoor rated) with gaskets	
STI-1250	Weather Stopper without horn flush mount
STI-3150	Weather Stopper without horn with spacer
Accessories	
STI-3100	2" conduit spacer with 1/2" conduit entry (no gaskets included)
STI-1102	Replacement horn for cover with alarm