



**MR-2300-LCD**

**Remote Annunciator**

# INSTALLATION MANUAL

*Revision 2 082307*

*Document #: LT-1002SEC*

**WARNING:** *This manual contains information on limitations regarding product use and function and information on the limitations as to liability of the manufacturer. The entire manual should be read carefully.*



# Contents

---

Introduction .....	1
Mechanical Installation.....	2
Functional Setup .....	3
Jumpers .....	3
Potentiometer.....	3
DIP Switches.....	4
Wiring.....	5
Specifications & Features .....	7
Enclosure .....	7
Electrical Specifications .....	7
Current Drain for Battery Calculations .....	7
Operating Instructions.....	8
Warranty .....	9

## Introduction

The MR-2300-LCD is a remote annunciator used for the MR-2300 Series Fire Alarm Panels. It provides remote access to the fire alarm panel.



**Note:** Configuration of the MR-2300 series fire alarm panel from this remote annunciator is not allowed.

The MR-2300-LCD has an LCD display, common feature LEDs and pushbuttons, as well as an alpha numeric keypad for the LCD.

The MR-2300-LCD comes complete with an enclosure and can be surface mounted.

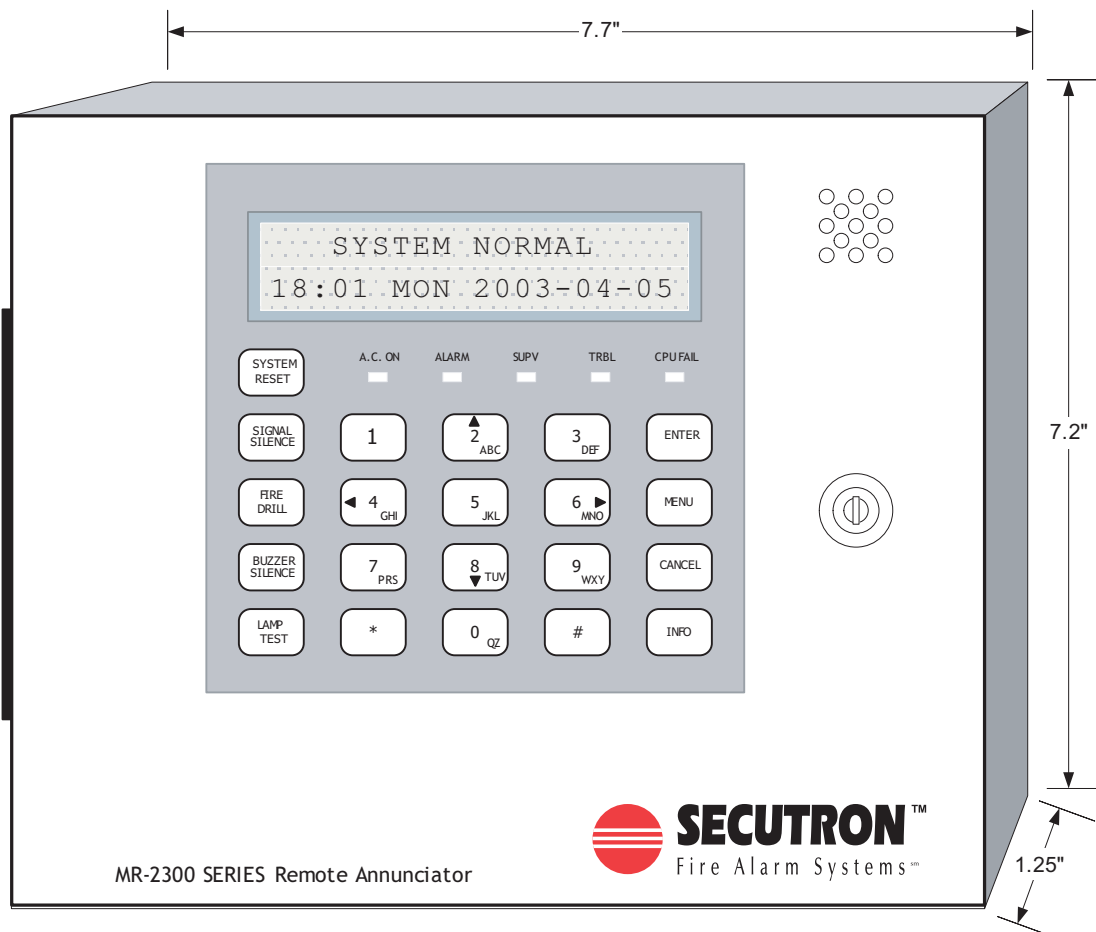

Each MR-2300-LCD has its own address. Addresses available are 1 to and including 6. The buttons on the left side may be individually disabled if required, by setting DIP Switch SW31, see Functional Setup section following.

This annunciator may be selected to operate as an ancillary device using DIP Switch SW31-6 to disable all buttons except, Lamp Test, Buzzer Silence, Info and Arrow Buttons.



**Note:** This option, if selected takes priority over any other selections made on DIP Switch SW31.

## Mechanical Installation

To mount the MR-2300-LCD open the front door, remove the dead front plate and mount the backbox to the wall using the four screws provided. This enclosure may also be mounted to a 4" square electrical box. There are two conduit areas provided at the bottom center of the enclosure. With the dead front plate removed, you may do the functional setup and wiring before replacing the dead front, see following sections.

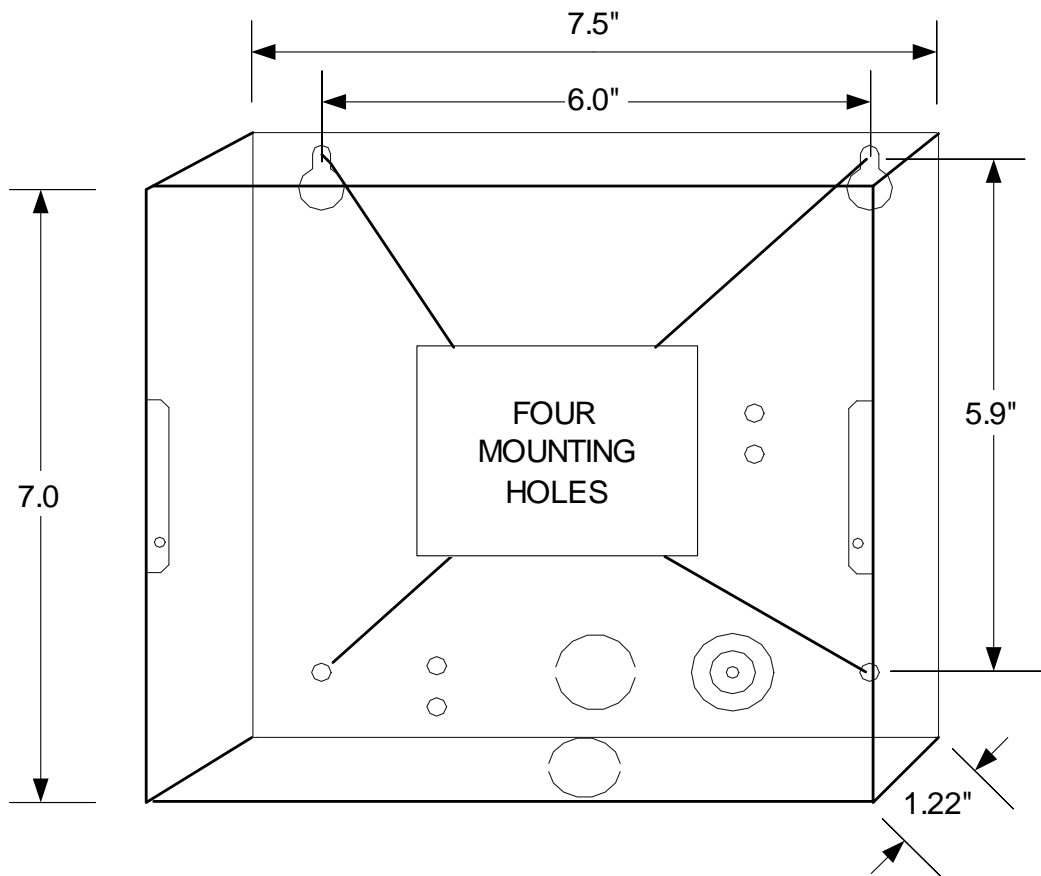

# Functional Setup

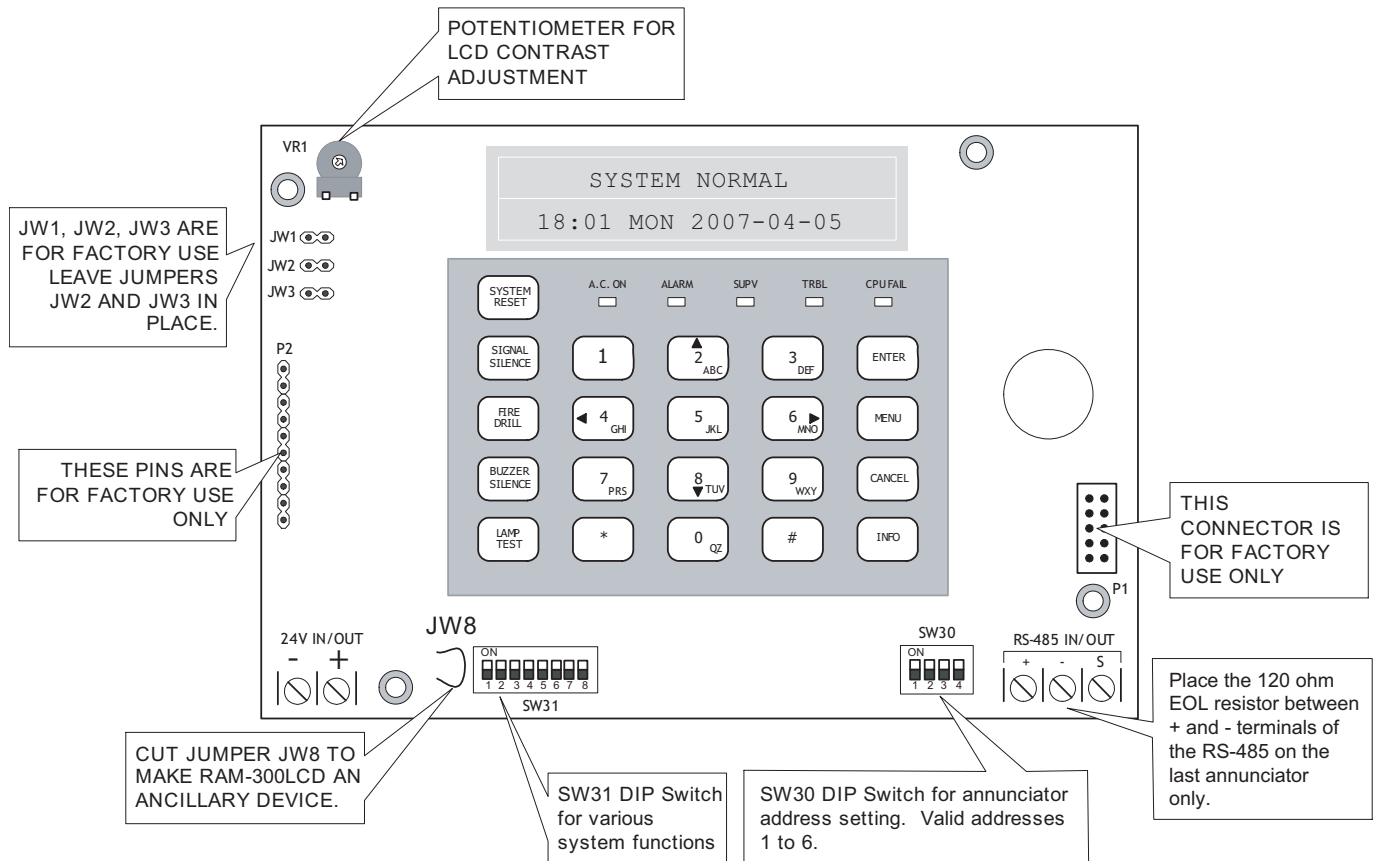

## Jumpers

Jumper	Jumper Function
JW1	FACTORY USE ONLY
JW2	FACTORY USE ONLY
JW3	FACTORY USE ONLY
JW8	CUT jumper to set the MR-2300-LCD as an ancillary device. Use NP-2051 blank labels to cover the System Reset, Signal Silence, Fire Drill, Enter, Menu and Cancel buttons for the Ancillary Device Feature. Only Buzzer Silence, Lamp Test and Info are used.

## Potentiometer

VR1 is a potentiometer used for LCD contrast adjustment and is located in the top left corner of the MR-2300-LCD board.

## DIP Switches

There are two DIP switches to be set. SW30 is found at the bottom right corner of the board and is used to select the annunciator address. Valid addresses are 1 to 6 inclusive for MR-2300. Set address as follows:

### MR-2300-LCD Address DIP Switch Setup

Address	SW30-1	SW30-2	SW30-3
1	ON	OFF	OFF
2	OFF	ON	OFF
3	ON	ON	OFF
4	OFF	OFF	ON
5	ON	OFF	ON
6	OFF	ON	ON
7	NOT USED		



**Note:** SW30-4 DIP switch is not used.

DIP switch SW31 is found at the bottom left hand corner and is used to select a number of features. DIP switch SW31 is set as follows:

DIP Switch SW31	Position	Function
1	ON	Disable System Reset Button
1	OFF	Enable System Reset Button
2	ON	Disable Signal Silence Button
2	OFF	Enable Signal Silence Button
3	ON	Disable Fire Drill Button
3	OFF	Enable Fire Drill Button
4	ON	Disable Lamp Test Button
4	OFF	Enable Lamp Test Button
5	ON	Disable Buzzer Silence Button
5	OFF	Enable Buzzer Silence Button
6	NOT USED	
7	ON	16 bit checksum (if available)
7	OFF	8 bit checksum (for MR-2300)
8	NOT USED	

## Wiring

To wire the MR-2300-LCD, you must first remove the dead front plate. Wire from the last MR-2300-LCD to the next MR-2300-LCD and so on; then from the first MR-2300-LCD to the MR-2300 Fire Alarm Panel. There are only two connections to be made, one for power and the RS-485 loop. Replace the dead front plate once all functional setup and wiring is complete.

The **RS-485 Wiring** to the MR-2300-LCD is recommended to be ***Twisted Shielded Pair***. The wire gauge may be

- 22 AWG up to 2000 ft.
- 20 AWG up to 4000 ft.

The 24V DC field wiring needs to be of an appropriate gauge for the number of annunciators and the total wiring run length. See Current Drain for Battery Calculations on page 7 and calculate the *Maximum* current for all annunciators summed together.



**Note:** All circuits are power limited and must use type FPL, FPLR or FPLP Power Limited Cable.



**CAUTION:** Accidentally connecting any of the 24V DC wires to the RS-485 wiring will result in damage to the Annunciator and/or to the Fire Alarm Control Panel to which it is connected.

Total Maximum Current for all Annunciators	Maximum Wiring Run to Last Annunciator								Max. Loop Resistance
	18AWG		16AWG		14AWG		12AWG		
Amperes	ft	m	ft	m	ft	m	ft	m	Ohms
0.12	1180	360	1850	567	3000	915	4250	1296	15
0.30	470	143	750	229	1200	366	1900	579	6
0.60	235	71	375	114	600	183	850	259	3
0.90	156	47	250	76	400	122	570	174	2
1.20	118	36	185	56	300	91	425	129	1.5
1.50	94	29	150	46	240	73	343	105	1.2
1.70	78	24	125	38	200	61	285	87	1.0

The MR-2300-LCD is wired as shown below. Additional MR-2300-LCDs are wired in the same manner, make sure **ONLY** the last MR-2300-LCD has the 120 ohm E.O.L. resistor connected to the RS-485 positive and negative terminals.

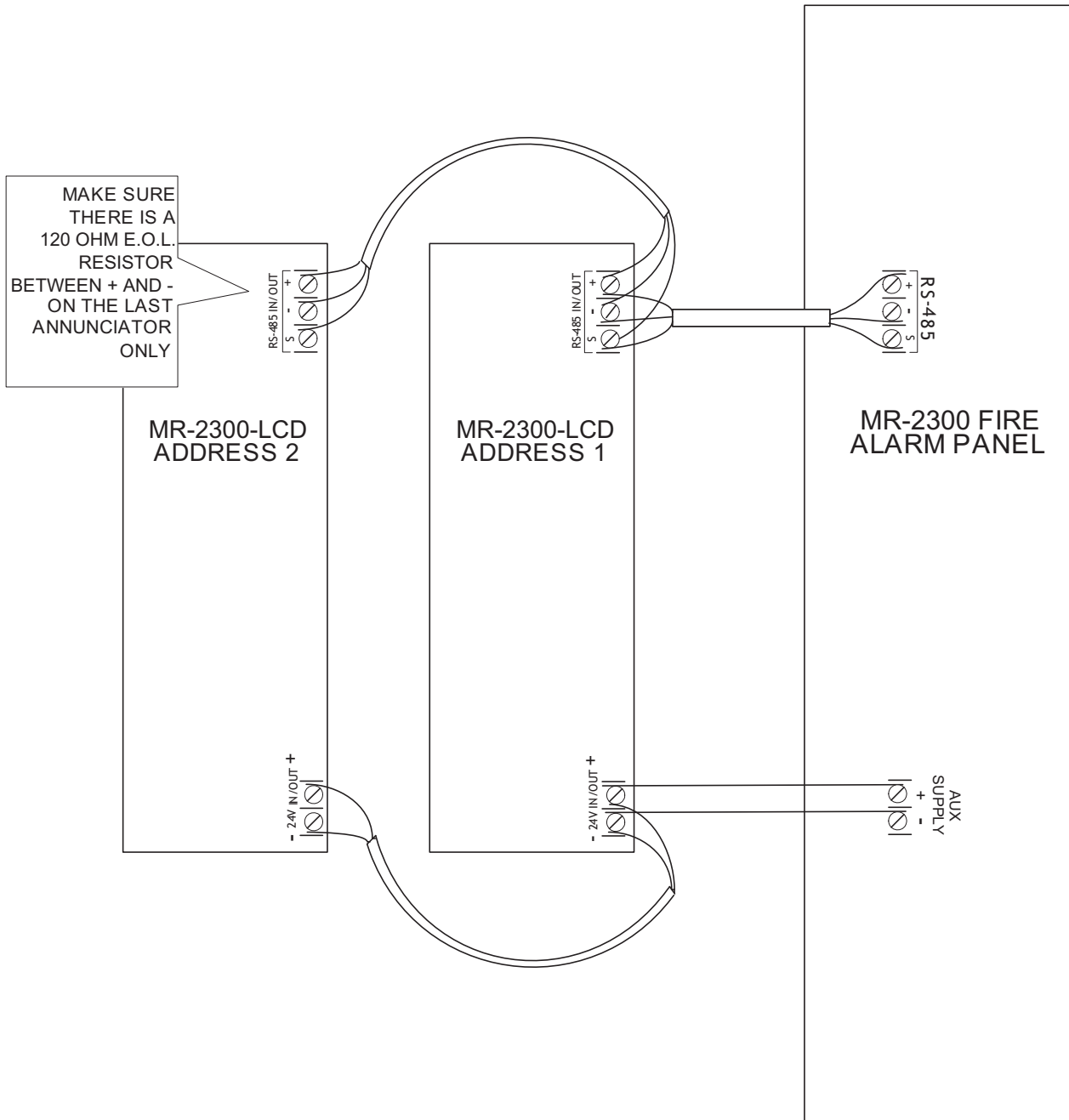

# Specifications & Features

---

## Enclosure

Enclosure may be mounted on a standard 4" square electrical box or on a wall.

## Electrical Specifications

- 24 VDC nominal voltage.
- LCD Display, Pushbutton Controls and LED indicators.
- Local Buzzer, Indicators (AC-On, Alarm, Supervisory, Trouble and CPU Fail), and Controls (System Reset, Signal Silence, Fire Drill, Buzzer Silence and Lamp Test,).
- Annunciation of up to 16 Points.
- Not Expandable.
- Standby 16 mA Max., Alarm 40mA Max. All LEDs illuminated 40 mA Max.

## Current Drain for Battery Calculations

The maximum normal current drain will be during Lamp Test when all lamps are illuminated on one chassis at a time. Thus the currents are:

- **Normal Standby** = 16 mA
- **Maximum** = 40 mA

The **Normal Standby Current** is used for battery size calculations (see the MR-2300 Series Fire Alarm Control Panel manual for battery calculations) and includes the current drain for the Trouble Buzzer, Trouble LED, and one Alarm LED. The **Maximum Current** is used to calculate the wire size (see *Wiring* section above).

# Operating Instructions

---

**Normal:** All indicators are normally OFF except for the green A.C. ON light which illuminates steadily.

**Alarm:** Operate Alarm Initiating Devices to activate Indicating Appliances. Signals will sound, common alarm will illuminate red.

**Silencing of Alarm:** Press Signal Silence button momentarily to silence all audible signals.



**Note:** The signal silencing function may be inhibited for up to one minute. The Signal silence button will not operate until the inhibit period has expired.

**Waterflow:** Indicating appliances and other output circuits that are activated in response to an alarm initiated by a designated Waterflow Zone cannot be silenced (manual or automatic).

**Supervisory:** Activation of any initiating devices for supervisory will sound the buzzer continuously. The Common supervisory indicator will illuminate amber (steady). The Common Supervisory indicator remains "ON" when the buzzer is silenced.

**System Reset:** Press the Reset button momentarily to restore normal operation. All alarm indicators will extinguish & all latched functions are restored.

**Trouble:** Any system trouble will sound the buzzer intermittently and common Trouble indicator will flash amber until the fault is corrected. Specific types of trouble will be indicated by the LCD display by pressing the INFO button. Call for service.

**Fire Drill:** Press the Fire Drill button momentarily to sound all audible signals without initiating an alarm. Press the button again for normal system operation. **Note:** *Auxiliary relays will not operate when Fire Drill is operated.*

**Lamp Test:** Press the Lamp Test button momentarily to test all indicators. All indicators should be lit and buzzer will sound. Holding down this button will display the firmware version.

**CPU Fail LED:** Will illuminate amber for an inboard CPU error.

**Menu Button:** Press the Menu button to access the associated MR-2300 Series Fire Alarm Panel. The Menu button operates as it does on the main MR-2300 Series Fire Alarm Panel, refer to the fire alarm manual for further explanation. Use the keypad arrow keys (2, 4, 6 and 8) to scroll through the menu. Configuration of the fire alarm panel cannot be accessed from the MR-2300-LCD.

**Enter, Cancel and Info Buttons:** The Enter and Cancel buttons are used to input and erase data for the fire alarm panel and the Info button is used to view the fire alarm panel logs.

**Keypad:** The numbered keys and/or letter keys function as they do at the MR-2300 Series Fire Alarm Panel, refer to the fire alarm manual for further explanation.

# Warranty & Warning Information

---

## Warning Please Read Carefully

Note to End Users: This equipment is subject to terms and conditions of sale as follows:

### Note to Installers

This warning contains vital information. As the only individual in contact with system users, it is your responsibility to bring each item in this warning to the attention of the users of this system. Failure to properly inform system end-users of the circumstances in which the system might fail may result in over-reliance upon the system. As a result, it is imperative that you properly inform each customer for whom you install the system of the possible forms of failure.

### System Failures

This system has been carefully designed to be as effective as possible. There are circumstances, such as fire or other types of emergencies where it may not provide protection. Alarm systems of any type may be compromised deliberately or may fail to operate as expected for a variety of reasons. Some reasons for system failure include:

#### •*Inadequate Installation*

A Fire Alarm system must be installed in accordance with all the applicable codes and standards in order to provide adequate protection. An inspection and approval of the initial installation, or, after any changes to the system, must be conducted by the Local Authority Having Jurisdiction. Such inspections ensure installation has been carried out properly.

#### •*Power Failure*

Control units, smoke detectors and many other connected devices require an adequate power supply for proper operation. If the system or any device connected to the system operates from batteries, it is possible for the batteries to fail. Even if the batteries have not failed, they must be fully charged, in good condition and installed correctly. If a device operates only by AC power, any interruption, however brief, will render that device inoperative while it does not have power. Power interruptions of any length are often accompanied by voltage fluctuations which may damage electronic equipment such as a fire alarm system. After a power interruption has occurred, immediately conduct a complete system test to ensure that the system operates as intended.

#### •*Failure of Replaceable Batteries*

Systems with wireless transmitters have been designed to provide several years of battery life under normal conditions. The expected battery life is a function of the device environment, usage and type. Ambient conditions such as high humidity, high or low temperatures, or large temperature fluctuations may reduce the expected battery life. While each transmitting device has a low battery monitor which identifies when the batteries need to be replaced, this monitor may fail to operate as expected. Regular testing and maintenance will keep the system in good operating condition.

#### •*Compromise of Radio Frequency (Wireless) Devices*

Signals may not reach the receiver under all circumstances which could include metal objects placed on or near the radio path or deliberate jamming or other inadvertent radio signal interference.

#### •*System Users*

A user may not be able to operate a panic or emergency switch possibly due to permanent or temporary physical disability, inability to reach the device in time, or unfamiliarity with the correct operation. It is important that all system users be trained in the correct operation of the alarm system and that they know how to respond when the system indicates an alarm.

#### •*Automatic Alarm Initiating Devices*

Smoke detectors, heat detectors and other alarm initiating devices that are a part of this system may not properly detect a fire condition or signal the control panel to alert occupants of a fire condition for a number of reasons, such as: the smoke detectors or heat detector may have been improperly installed or positioned; smoke or heat may not be able to reach the alarm initiating device, such as when the fire is in a chimney, walls or roofs, or on the other side

of closed doors; and, smoke and heat detectors may not detect smoke or heat from fires on another level of the residence or building.

•*Software*

Most Secutron products contain software. With respect to those products, Secutron does not warranty that the operation of the software will be uninterrupted or error-free or that the software will meet any other standard of performance, or that the functions or performance of the software will meet the user's requirements. Secutron shall not be liable for any delays, breakdowns, interruptions, loss, destruction, alteration or other problems in the use of a product arising out of, or caused by, the software.

Every fire is different in the amount and rate at which smoke and heat are generated. Smoke detectors cannot sense all types of fires equally well. Smoke detectors may not provide timely warning of fires caused by carelessness or safety hazards such as smoking in bed, violent explosions, escaping gas, improper storage of flammable materials, overloaded electrical circuits, children playing with matches or arson.

Even if the smoke detector or heat detector operates as intended, there may be circumstances when there is insufficient warning to allow all occupants to escape in time to avoid injury or death.

•*Alarm Notification Appliances*

Alarm Notification Appliances such as sirens, bells, horns, or strobes may not warn people or waken someone sleeping if there is an intervening wall or door. If notification appliances are located on a different level of the residence or premise, then it is less likely that the occupants will be alerted or awakened. Audible notification appliances may be interfered with by other noise sources such as stereos, radios, televisions, air conditioners or other appliances, or passing traffic. Audible notification appliances, however loud, may not be heard by a hearing-impaired person.

•*Telephone Lines*

If telephone lines are used to transmit alarms, they may be out of service or busy for certain periods of time. Also the telephone lines may be compromised by such things as criminal tampering, local construction, storms or earthquakes.

•*Insufficient Time*

There may be circumstances when the system will operate as intended, yet the occupants will not be protected from the emergency due to their inability to respond to the warnings in a timely manner. If the system is monitored, the response may not occur in time enough to protect the occupants or their belongings.

•*Component Failure*

Although every effort has been made to make this system as reliable as possible, the system may fail to function as intended due to the failure of a component.

•*Inadequate Testing*

Most problems that would prevent an alarm system from operating as intended can be discovered by regular testing and maintenance. The complete system should be tested as required by national standards and the Local Authority Having Jurisdiction and immediately after a fire, storm, earthquake, accident, or any kind of construction activity inside or outside the premises. The testing should include all sensing devices, keypads, consoles, alarm indicating devices and any other operational devices that are part of the system.

•*Security and Insurance*

Regardless of its capabilities, an alarm system is not a substitute for property or life insurance. An alarm system also is not a substitute for property owners, renters, or other occupants to act prudently to prevent or minimize the harmful effects of an emergency situation.

**IMPORTANT NOTE:** End-users of the system must take care to ensure that the system, batteries, telephone lines, etc. are tested and examined on a regular basis to ensure the minimization of system failure.

## Limited Warranty

Secutron Inc. warrants the original purchaser that for a period of two years from the date of manufacture, the product shall be free of defects in materials and workmanship under normal use. During the warranty period, Secutron Inc. shall, at its option, repair or replace any defective product upon return of the product to its factory, at no charge for labor and materials. Any replacement and/or repaired parts are warranted for the remainder of the original warranty or ninety (90) days, whichever is longer. The original owner must promptly notify Secutron Inc. in writing that there is defect in material or workmanship, such written notice to be received in all events prior to expiration of the warranty period.

### International Warranty

The warranty for international customers is the same as for any customer within Canada and the United States, with the exception that Secutron Inc. shall not be responsible for any customs fees, taxes, or VAT that may be due.

### Conditions to Void Warranty

This warranty applies only to defects in parts and workmanship relating to normal use. It does not cover:

- damage incurred in shipping or handling;
- damage caused by disaster such as fire, flood, wind, earthquake or lightning;
- damage due to causes beyond the control of Secutron Inc. such as excessive voltage, mechanical shock or
- water damage;
- damage caused by unauthorized attachment, alterations, modifications or foreign objects;
- damage caused by peripherals (unless such peripherals were supplied by Secutron Inc.);
- defects caused by failure to provide a suitable installation environment for the products;
- damage caused by use of the products for purposes other than those for which it was designed;
- damage from improper maintenance;
- damage arising out of any other abuse, mishandling or improper application of the products.

## Warranty Procedure

To obtain service under this warranty, please return the item(s) in question to the point of purchase. All authorized distributors and dealers have a warranty program. Anyone returning goods to Secutron Inc. must first obtain an authorization number. Secutron Inc. will not accept any shipment whatsoever for which prior authorization has not been obtained. NOTE: Unless specific pre-authorization in writing is obtained from Secutron management, no credits will be issued for custom fabricated products or parts or for complete fire alarm system. Secutron will at its sole option, repair or replace parts under warranty. Advance replacements for such items must be purchased.

Note: Secutron Inc.'s liability for failure to repair the product under this warranty after a reasonable number of attempts will be limited to a replacement of the product, as the exclusive remedy for breach of warranty.

## Disclaimer of Warranties

This warranty contains the entire warranty and shall be in lieu of any and all other warranties, whether expressed or implied (including all implied warranties of merchantability or fitness for a particular purpose) And of all other obligations or liabilities on the part of Secutron Inc. neither assumes nor authorizes any other person purporting to act on its behalf to modify or to change this warranty, nor to assume for it any other warranty or liability concerning this product.

This disclaimer of warranties and limited warranty are governed by the laws of the province of Ontario, Canada.

## Out of Warranty Repairs

Secutron Inc. will at its option repair or replace out-of-warranty products which are returned to its factory according to the following conditions. Anyone returning goods to Secutron Inc. must first obtain an authorization number. Secutron Inc. will not accept any shipment whatsoever for which prior authorization has not been obtained.

Products which Secutron Inc. determines to be repairable will be repaired and returned. A set fee which Secutron Inc. has predetermined and which may be revised from time to time, will be charged for each unit repaired.

Products which Secutron Inc. determines not to be repairable will be replaced by the nearest equivalent product available at that time. The current market price of the replacement product will be charged for each replacement unit.

**WARNING: Secutron Inc. recommends that the entire system be completely tested on a regular basis. However, despite frequent testing, and due to, but not limited to, criminal tampering or electrical disruption, it is possible for this product to fail to perform as expected.**

**NOTE: Under no circumstances shall Secutron Inc. be liable for any special, incidental, or consequential damages based upon breach of warranty, breach of contract, negligence, strict liability, or any other legal theory. Such damages include, but are not limited to, loss of profits, loss of the product or any associated equipment, cost of capital, cost of substitute or replacement equipment, facilities or services, down time, purchaser's time, the claims of third parties, including customers, and injury to property.**

**SECUTRON MAKES NO WARRANTY OF MERCHANTABILITY OR FITNESS FOR A PARTICULAR PURPOSE WITH RESPECT TO ITS GOODS DELIVERED, NOR IS THERE ANY OTHER WARRANTY, EXPRESSED OR IMPLIED, EXCEPT FOR THE WARRANTY CONTAINED HEREIN.**



© 2007 Secutron, Inc.

No part of this publication may be reproduced, transmitted, transcribed, stored in a retrieval system, or translated into any language or computer language, in any form by any means electronic, magnetic, optical, chemical, manual, or otherwise without the prior consent of Secutron.

**Canada**  
25 Interchange Way  
Vaughan, ON L4K 5W3  
Tel: (888) SECUTRON  
(888) 732-8876  
Fax: (905) 660-4113

**U.S.A**  
60 Industrial Parkway, PMB 278  
Cheektowaga, New York 14227  
Tel: (888) SECUTRON  
(888) 732-8876  
Fax: (905) 660-4113