



MR-2900
Fire Alarm Control Unit

INSTALLATION MANUAL

September 2009
Document #: LT-2010 Rev.2

WARNING: *This manual contains information on limitations regarding product use and function and information on the limitations as to liability of the manufacturer. The entire manual should be read carefully.*

Table of Contents

1.0 Technical Information	1
1.1 General	1
1.2 Main Circuit Board	1
1.3 Front Panel	3
1.4 Input Circuits	3
1.5 Input Circuit Modules	4
1.6 Terminal Board	5
1.7 Annunciator Strip	5
1.8 Power Supply	6
1.9 Enclosure	6
1.10 Networking	6
1.11 Optional Integrated Printer	7
2.0 Installation	8
2.1 Unpacking the MR-2900	8
2.2 Mounting and Assembling the MR-2900	9
2.3 Internal Assembly	10
2.4 Wiring	12
3.0 Technical Specifications	23
4.0 Parts List	25
5.0 Appendix A: Power Supply and Battery Calculations	26
5.1 General	27
6.0 Appendix B: ULC Listed Compatible Smoke Detectors	28
6.1 ULC Listed Compatible Addressable Devices	30
7.0 Appendix C: UL Listed Compatible Devices	31
7.1 UL Listed “Class B” Smoke Detectors	31
7.2 UL Listed “Class A” Smoke Detectors	34
7.3 UL Listed Notification Appliances	35
7.5 UL Listed Analog Addressable Devices	42
7.6 UL Listed Compatible Door Holder/Releasers	43
8.0 Appendix D: Interconnection to Other Equipment	44
8.1 Radionics 2071C and 2071AC	44
8.2 Silent Knight 5104	45
8.3 CTM City Tie Module	46
8.4 Keltron 3158 TTM	47
9.0 Warranty & Warning Information	48
9.1 Warning Please Read Carefully	48
9.2 Limited Warranty	50
9.3 Warranty Procedure	50
9.4 Disclaimer of Warranties	50
9.5 Out of Warranty Repairs	51

List of Figures and Tables

Figure 1: Basic Network Communication Flow	6
Figure 2: MR-2900 Exploded View	8
Figure 3: MR-2900 and MR-2944 in a Network	10
Figure 4: Back Box Dimension and Knockout Reference	11
Figure 5: 120VAC Power Connection	12
Figure 6: 240VAC Power Connection	12
Figure 7: Conventional Style B (Class B) Wiring	12
Figure 8: Conventional Style A (Class A) Wiring	13
Figure 9: Smoke Detector Circuit Wiring, Style B (Class B) Wiring	13
Figure 10: Smoke Detector Circuit Wiring, Style D (Class A) Wiring	13
Figure 11: Normally Closed Wiring	14
Figure 12: Normally Open Wiring	14
Figure 13: Addressable Style 4(Class B) Wiring	14
Figure 14: Addressable Style 6 (Class A) Wiring	15
Figure 15: MRI-M500M Wiring	16
Figure 16: MRI-M501 Wiring	16
Figure 17: MRI-M502M Wiring	17
Figure 18: MRI-M500S Wiring for Signalling Circuits.....	17
Figure 19: MRI-M500R Wiring for Form C Relay Use	18
Figure 20: MRI-M500X Wiring	18
Figure 21: Style Y (Class B) Bell Circuit Wiring	18
Figure 22: Style Z (Class A) Bell Circuit Wiring	19
Figure 23: Relay	19
Figure 24 Auxiliary Power Connections	19
Figure 25: Ribbon Cable Installation	20
Figure 26: Standard Network Wiring	20
Figure 27: RS-232 Network Wiring	21
Figure 28: MR-2614, MR-2644, MR-2900-DACT and MR-2900-CITY Wiring	22
Figure 29: EVAX System Wiring	22
Figure 30: MR-2900 and Radionics 2071C/2071AC Wiring	44
Figure 31: MR-2900 and Radionics 2071C/2071AC Wiring with addressable module substituted for alarm relay	44
Figure 32: MR-2900 and Silent Knight 5104 Dialer Wiring	45
Figure 33: MR-2900 and Silent Knight 5104 Dialer Wiring with addressable module substituted for common alarm relay	45
Figure 34: MR-2900 and Silent Knight 5104 Dialer Wiring with addressable module substituted for common supervisory relay	45
Figure 35: CTM City Tie Module Wiring	46
Figure 36: MR-2900 and Keltron 3158 TTM Wiring	47
Table 1: Input Circuit Module Compatibility	4
Table 2: Maximum Wire Lengths for Conventional Input Circuits	14
Table 3: Maximum Wiring Length for Addressable Circuits	15
Table 4: Maximum Wire Lengths for Bell Circuits	19
Table 5: Maximum Capacitance for Network Baud Rates	21

1.0 Technical Information

1.1 General

The MR-2900 Fire Alarm Control Unit provides capability for up to 24 Input Circuits, 8 Polarity Reversing Bell Circuits, network capabilities (with use of an MR-2910 Network Board) and 4 General Purpose Form "C" Relays as well as system operated relays for alarm, trouble and supervisory indication. If the MR-2900 is ordered with a printer, it is ordered under the panel number MR-2920.

The Control Unit can be networked to provide additional input circuits, visual zones, bell circuits and relays. Up to 40 Units (Control and/or Annunciator) can be connected to form the network. The network is a Style 7 (Data Communications Link, Redundant (DCLR)) loop.

All programming is done through the LCD and keypad. Input circuit programming and special features, day/night mode, etc., are done from an externally generated database, while system parameters are programmed from the LCD and keypad. For programming information, refer to *LT-2011 MR-2900 Programming Manual*.

The basic MR-2900 Fire Alarm Control Unit consists of the:

- Main Circuit Board (MR-2931)
- Terminal Board (MR-2936)
- Annunciator Strip (MR-2902)
- Power Supply (MR-2905)
- Door Assembly (MR-2972)
- Back Box (MR-2971)

1.2 Main Circuit Board

The Main Circuit Board (MR-2931) provides system controls and visual indications, and contains the system processor, programming port, printer port and non-volatile memory for system firmware. Software is installed on the main board for critical functions such as programmable logic and timing functions and non-critical functions, such as custom zone and devices messages. All jumpers on the board are for diagnostic and test purposes. There are 6 LEDs in the middle of the right edge for diagnostic purposes.

The visual display consists of a series of LEDs for common system indication of power, alarm, supervisory, and trouble. An LED clock display is provided to display real time. The flashing colon of the clock provides visual indication of system processor operation. The clock also displays dashes if a major error/change occurs. When this happens, the system requires a Hard reboot. A Hard reboot is done by pressing and releasing the button inside the top of the inner door assembly.

The Circuit Board has an 80-character alphanumeric LCD. It provides descriptions for inputs, display of archived events, first/last device in alarm, custom messages, etc. The keypad is used to scroll through the display.

There are three connectors on the bottom of the Main Circuit Board, an audio output jack, a 9-pin service terminal port and a 25-pin printer port. The ports are discussed below. The audio jack produces various tones for use in walktesting of the system.

Communication Ports

The Control Unit has 6 communication ports available:

- Port #1- network (Proprietary)
- Port #2- network (Proprietary)
- Port #3- general purpose (Proprietary)
- Port #4- service terminal (RS232 - DB9)
- Port #5- printer interface, Parallel (IBM/Centronics - DB25)
- Port #6- serial printer interface (RS-232)

Ports 1 to 3 use the terminal strip on the Terminal Board for connection. Ports 4 and 5 use the connectors mounted on the bottom of the Main Circuit Board. Port 6 uses a connector on the top of the Terminal Board. It is for the optional factory installed MR-2920 strip printer.

The system network ports, Ports 1 and 2, allow for the networking of units. Up to 40 units (Control and/or Annunciator) can be networked together. The network wiring is a Style 7 (DCLR) loop layout. An MR-2910 Series Network Board is required by each Control Unit to use these ports.

Port 3 is available for different uses depending upon the operating program loaded in the panel. Different uses require different variants of the operating program. Typical uses are a central station connection or remote LED annunciation of system status. The operation of this port is software defined and requires the use of an MR-2109-x communications board. The MR-2109-3 Driver is for communication to MR-2614, MR-2644, and the following dialers MR-2900-DACT and MRDL. The MR-2109-4 Driver is for communication to the MV-2700 voice system.

The service terminal port, Port 4, permits the downloading and uploading of custom software, such as device messages and I/O functions. It is intended for temporary connection to provide supplementary information during servicing of the panel.

The parallel printer port, Port 5, connects to any standard parallel printer. The system prints every occurrence as it happens. It is intended for temporary connection and can be used for system commissioning and testing by producing a printed log of received events. This can then be checked against a log of tests performed to confirm operation.

The serial printer interface, Port 6, is for the optional factory installed strip printer.



Note: If either of the printers or the service terminal printer screen is stalled, it causes the other printers to stall.

1.3 Front Panel

The system controls consist of 12 system switches and a 20 position alphanumeric keypad. The 12 system switches are factory defined for operations such as alarm acknowledge, signal silence and system reset. The 20-position keypad is used for:

- technical functions
- system/detector maintenance
- history recall
- device/circuit disarming
- manual operation of addressable output modules, relay modules and bell circuits

1.4 Input Circuits

There are seven classes of conventional input circuits supported by the Control Unit. Not all classes are supported by all the Conventional Input Circuit Modules. See *Table 1: Input Circuit Module Compatibility on page 4* to determine which circuits are supported by each module.

Conventional Input Circuits

- **"Class A"** - This is a 4 wire supervised circuit supporting normally open contact initiating devices. Two-wire smoke detectors are not supported by this type of circuit. A "Class A" circuit requires two of the input circuits, one for the high loop and one for the low loop.
- **"Class B"** - This is a 2 wire supervised circuit supporting only normally open contact initiating devices and using a 470 Ω End-of-Line Resistor, model EOL-471. Two-wire smoke detectors cannot be used on this type of circuit.
- **Smoke Detector** - This is a supervised circuit supporting two-wire smoke detectors only. Both "Class B", using the 3.9K Ω Resistor (EOL-392), and "Class A" wiring is available depending upon the Input Circuit Module used (see *1.5 Input Circuit Modules on page 4*). Contact initiating devices cannot be used with this type of circuit. A short is reported as a trouble, not as an Alarm.
- **Smoke Detector and Contact Device** - This is a supervised circuit supporting two-wire smoke detectors and normally open contact initiating devices. This circuit is wired the same as a Smoke Detector circuit. Shorts on this type of circuit are reported as an Alarm, not as a trouble.
- **Normally Open** - This is an unsupervised 2-wire circuit. Normally Open circuits are always Supervisory circuits. This circuit is listed by UL for connection to other control equipment through less than 20 feet of conduit.
- **Normally Closed** - This is an unsupervised 2-wire circuit. This circuit shall not be used to monitor fire alarm or supervisory initiating devices. This circuit is listed by UL for connection to other control equipment through less than 20 feet of conduit.



Note: The Control Unit shows spurious alarms and troubles due to any mismatches between the programmed circuit classes and the actual field wiring.

Addressable Input Circuits

There are two classes of addressable input circuits supported by the Control Unit:

- **"Class A" (Style 6)** - This is a 4 wire circuit supporting addressable detectors and modules. It requires two input circuits, one for signal out and one for signal return. Up to 99 detectors and up to 99 modules can be connected to the circuit.
- **"Class B" (Style 4)** - This is a 2 wire circuit supporting addressable detectors and modules. Up to 99 detectors and up to 99 modules can be connected to the circuit.



Note: Applicable codes and standards as well as good engineering practices must be considered with regards to the number of addressable devices connected to one addressable circuit. Isolation modules (MRI-500X) should be used whenever more than one fire zone is protected by one addressable circuit.

1.5 Input Circuit Modules

There are five types of Input Circuit Modules. Table 1 circuit classes are supported by each conventional module. All Input Circuit Modules control eight of the input circuits, one of circuits 1 to 8, 9 to 16 or 17 to 24. Any of the Input Modules can be used to control circuits 9 to 16, and circuits 17 to 24. Addressable Input Modules do not physically fit in the location for circuits 1 to 8.

Ground fault conditions occurring on the input circuits are indicated as to the circuit of origin.

Conventional Input Modules

- **Model MR-2928** - supports all seven classes of conventional circuits. Smoke detector circuits are current limited to 80 mA while all other circuits are current limited to 10 mA.



Note: This board does not support 2-wire smoke detectors on a "Class A" circuit.

- **Model MR-2938** - supports only "Class A" 2-wire smoke detectors circuits. All circuits are current limited to 80 mA.

Table 1: Input Circuit Module Compatibility

	MR-2928	MR-2938
Class A (Contact)		✓
Class B (Contact)	✓	
Smoke Detector	"Class B" Only	"Class A" Only
Smoke Detector and Contact Device	"Class B" Only	"Class A" Only
Normally Open	✓	
Normally Closed	✓	
Dual End-of-Line	✓	

Addressable Input Modules

- **Model MR-2929** - supports both of 8 addressable Style 4 (Class B) circuits and 4 addressable Style 6 (Class A) circuits
- **Model MR-2909** - supports 8 addressable Style 4 (Class B) circuits.
- **Model MR-2919** - supports 4 addressable Style 6 (Class A) circuits.

1.6 Terminal Board

Field connections are terminated on the MR-2936 Terminal Board, which in addition to terminal blocks contains a portion of the circuitry for output circuits and relays. The Terminal Board includes connections for 24 input circuits, 8 supervised polarity reversing bell circuits, 4 general purpose Form "C" relays, 3 system Form "C" relays and 2 auxiliary power outputs. There is a five-pin terminal block on the bottom of the Terminal Board for connection of the optional factory installed printer.

There are two versions of the Terminal Board. The MR-2926 Terminal Board has 8 Class B bells circuits. The MR-2925 Terminal Board has 4 Class A bell circuits. The two versions are identical otherwise. The MR-2936 supports 8 Class B bell circuits and 8 Class A bell circuits when a MR-2937 Class A Converter Board is installed.

The bell circuits are rated at 1.5 A @ 24 VDC. They are power-limited and protected with solid state fuses.



Note: Maximum system loading and stand-by battery power must be considered when determining actual bell loading.

A 10 K end-of-line resistor, EOL-103, is required for supervision. Bell circuits are supervised for open, short and ground fault conditions. The panel activates bell circuits in two modes: Evacuation, which activates the bells continuously or with the temporal pattern as specified in ANSI S3.41 and ISO 8201 *Audible Emergency Evacuation Signal*; Alert, which activates the bells in a repeated 1½ s on and 3 s off.

The general purpose Form "C" relay operation is program defined. The relays have a power factor of .35 and are rated at 0.6A @ 30VAC / 2.0A @ 30VDC. The system defined Form "C" relays are for Alarm, Supervisory and Trouble indication. These relays have a power factor of .35 and are rated 1.0A @ 24VDC / 0.5A @ 30VAC. The Trouble relay is normally energized so that loss of both AC power and battery power is indicated. The N.O. and N.C. markings on the Trouble relay refer to this energized state.

The operation of the general purpose relays and bell circuits is totally program defined. It is possible to program the activation of circuits to any zone, group of zones, device, group of devices and to further inhibit the operation for a specifiable period of time. Any relays not programmed for use in either the database or LCD menu are available for auxiliary power reset, i.e. the relay toggles for a programmable time when the *Reset* key is pressed provided the programmed time is a value other than zero.

The auxiliary power outputs provide 24 VDC @ 135 mA each. They are supervised for shorts only. Any load attached to the auxiliary power outputs have to be considered when calculating stand-by battery size.

1.7 Annunciator Strip

The Annunciator Board (MR-2902) contains 24 sets of zone indicating LEDs. Individual LEDs are provided to display alarm, supervisory and trouble conditions by zone. The LED functions, from the left, are: Alarm (red), Supervisory (amber or yellow) and Trouble (yellow). The LEDs flash on status change and go to steady on acknowledge. The trouble LEDs turn on for both open circuit and ground fault with the specific fault indicated on the LCD.

1.8 Power Supply

The Power Supply (MR-2905) is rated at 8A unregulated, providing the system with primary DC power. It is complete with a battery charger rated at 2 A and battery supervision circuitry. The power supply and battery are located within the control unit back box.

Battery supervision uses true dynamic supervision circuitry to simulate a load condition approximately every 90 seconds to ensure that the battery is capable of handling the system load requirements on loss of primary power.

If the battery voltage drops below 19V it is disconnected to protect against damage from a deep discharge.

A second compartment adjacent to the power supply compartment is provided for 120 VAC terminations.



Note: Never disconnect or reconnect the batteries while AC power is off.

1.9 Enclosure

The enclosure for MR-2900 Control Unit consists of a back box complete with power supply, inner door assembly complete with main control board, and outer door assembly. The back box and door assemblies are fabricated from 1/16" steel. The outer door includes tempered glass window, hinge, and lock assembly. The back box provides necessary "knock out" type openings for conduit entry.

The back box dimensions are 14 1/2" Wide x 27 1/2" High x 4" Deep. The outer door assembly is 16 7/8" Wide x 29 1/2" High x 1 1/4" Deep. The details and dimensions of the enclosure and the MR-2920 Control Unit with integrated printer are detailed below in section 1.11.

1.10 Networking

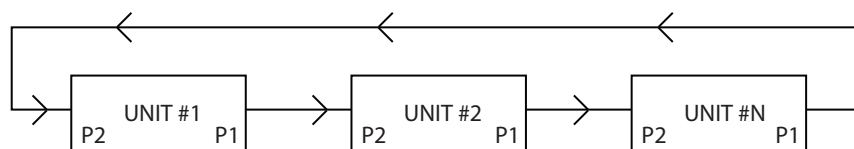

Figure 1: Basic Network Communication Flow

The basic MR-2900 Control Unit can be networked to other Control Units and Annunciator Units to provide additional input circuits, relays, bells and LEDs. Up to 40 units (Control and/or Annunciator) can be networked together.

The network is a Class A/Style 7 DCLR loop layout (see diagram). Each unit on the network requires the MR-2910 Network Board. Programming, servicing and testing are done at each individual unit. One Control Unit is designated, using the downloaded database, the Master Control Unit for the network. The Master Control Unit displays the Alarm List for the entire network if configured to do so. The Alarm List is programmable such that events may be archived locally on each individual panel or the archived collectively at the Master Panel. Please see the Programming Manual for further details.

There are four different MR-2910 boards available:

- MR-2910 Standard Version
- MR-2910-R1 Port 1 RS-232, Port 2 Standard
- MR-2910-R2 Port 1 Standard, Port 2 RS-232
- MR-2910-R12 RS-232 Version

Standard communications is for direct wire connections between units. RS-232 communications is for connection to fiber optic modems only. Refer to the MR-D1010 Installation Instructions (LT-2048) for information on connecting a fiber-optic network.

For NFAPA Style 7 connection of the network, port 1 of node 1 is connected to port 2 of node 2. Port 1 of node 2 is connected to port 2 of node 3. Port 1 of node 3 is connected to port 2 of node 4. Therefore, in general, port 1 of node N is connected to port 2 of node N+1. The last node of the network is handled differently.

For example, assume the system has a total of 30 nodes. In this case, the last node of the system is node 30. Port 1 of node 30 is connected to port 2 of node 1. Using this pattern the entire system would be connected according to NFAPA Style 7 for SLC connections.



Notes:

- Synchronized NAC devices can only function properly when driven by synchronization modules provided by the NAC device manufacturer. Please consult compatibility list within this manual.
- Follow the instructions provided with the synch modules for proper interconnection of these synch modules to the panel and to the NAC circuits.
- Synchronization across the network is not provided. Synchronization can only be done on a per sync module basis. Therefore, only NAC circuits connected to sync modules on the same node can be synchronized.
- Addressable NAC circuits cannot be synchronized.

1.11 Optional Integrated Printer

The MR-2900 Control Unit can be ordered integrated with the MR-2920 Printer. The MR-2920 Printer is a 20 column thermal printer. The Control Unit and Printer come in a larger cabinet (MR-2973) with the Printer in a compartment adjacent to the Control Unit. A compartment for 12 Ah batteries is located below the Control Unit and Printer.

The printer uses thermal paper. A Paper Advance button is on the right side of the Printer Compartment Cover. If the paper runs out, the printer stops printing. To start printing after installing paper, hold the Paper Advance button for a few seconds. Paper Out is reported to the Control Panel.

The Terminal Board, Power Supply Board and Toroid are in the main compartment of the back box in the same locations as they are in the regular back box. The backbox dimensions for the BB-2920B enclosure are 22 1/16" Wide x 27 1/2" High x 5 1/2" Deep. The outer door dimensions are 24 3/8" Wide x 29 1/2 High x 1 1/4" Deep.

2.0 Installation

2.1 Unpacking the MR-2900

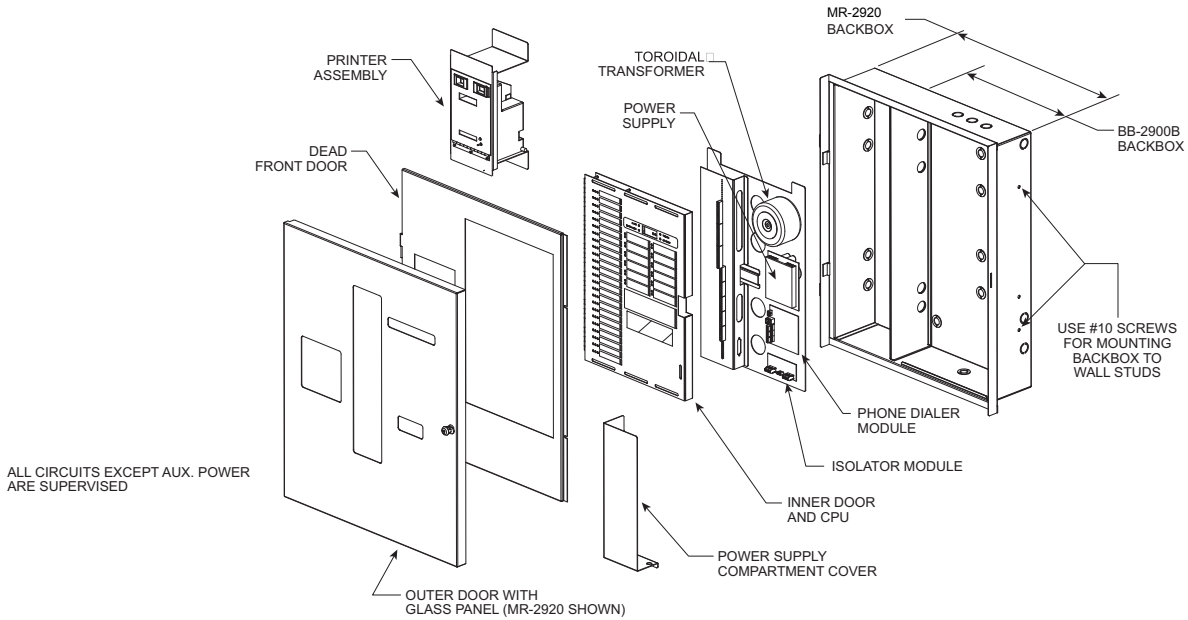

Figure 2: MR-2900 Exploded View

The basic MR-2900 package includes the following components:

Backbox

Outer door including:

- Lock
- Display window
- Dead front door

Inner Door Assembly including:

- Main PCB
- Display PCB
- Operating instruction insert
- Hotkey label insert
- Wiring label

Hardware backplate including:

- Power Supply
- Transformer
- Terminal Board

Hardware pack including:

- 8 x NAC EOL resistors
- Door keys (taped to outside of cabinet)
- Installation manual and operating manual

2.2 Mounting and Assembling the MR-2900



Note: All applicable codes and standards should be considered. Specific reference should be made to NFPA 72, or ULC-S524 and CEC Part 1 Section 32.

Surface and Flush Mounting

The MR-2900 can be mounted in either flush or surface mount installations. Before installing the MR-2900 Panel the following should be considered.

1. Determine a suitable location for mounting the FACP. Keep in mind that surrounding walls, fixtures, must not hinder access to internal components. etc.
2. Determine the size and location of conduit entrances. The Backbox provides various knockout locations, however should it be necessary to cut additional conduit entrances the electronics **must** be removed to avoid metal chip contamination. Reference the "Remove Electronics" paragraph on the following page.



Note: Removing the inner door, outer door, and plate-mounted electronics is recommended in all MR-2900 installations.

3. The enclosure must be mounted to provide a 135° (minimum) angle of rotation of the outer door to insure easy removal or assembly.
4. Mark placement of mounting hardware, drill holes and install plugs (if necessary).
5. Secure the FACP to the wall using hardware suitable to the wall construction. Support backbox in place while inserting hardware and ensure that the backbox is level and plumb before tightening.



Note: Please see the detailed diagram (Figure 2) for location of knockout and mounting holes.
Replacing the Outer Door

6. Unlock the Door with the key provided.
7. Detach the grounding strap (Qty: 2) from the backbox by removing the #6 flange nuts (Qty: 2) that are attached to the studs on the backbox. Reattach the #6 flange nuts (Qty: 2) to the studs to prevent them from getting lost or discarded.
8. Open the Door to approximately 135° and lift up to remove the outer door from the backbox, store door in a safe place.

Removing the MR-2900 Electronics

A. Removing the Dead Front

1. Remove the #6 flange nuts (Qty: 2) that lock down the dead front. Reattach the #6 flange nuts (Qty: 2) to the studs to prevent them from getting lost or discarded.
2. Open the dead front.
3. Detach the grounding strap (Qty: 1) from the backbox by removing the #6 flange nut (Qty: 1) that is attached to the stud on the backbox. Reattach the #6 flange nut (Qty: 1) to the stud to prevent it from getting lost or discarded.
4. Open the dead front approximately 90° and lift up to remove the dead front, store in a safe place.

B. Removing the Inner Door

1. Detach the two ribbon cables.
2. Remove the four (4) flange nuts and remove the inner door.
3. Detach the ground straps (Qty: 2)

C. Removing the Back Plate Electronics

1. Detach the ribbon cable.
2. Remove the #8 flange nuts (Qty: 4) from the studs on the backbox holding onto the back plate. Remove back Plate Electronic panel and store in a safe place. Reattach the #8 flange nuts to the studs to prevent them from getting lost or discarded.

2.3 Internal Assembly

- Attach AC wiring to the AC Terminal Block. Attach green ground wire to ground screw on backplate.



Note: Do not apply power to the unit until all doors, cables and wiring are installed and inspected.



Note: This AC circuit must be a separately fused dedicated circuit. It is recommended that the breaker be locked in the OFF position during installation.

- Place the batteries in the bottom right of the back box or into the battery box. DO NOT ATTACH BATTERIES UNTIL AFTER THE AC POWER HAS BEEN TURNED ON.
- Attach conduit to the back box as required using knockouts provided. Attach field wiring to the system. The section below describes how each type of circuit is to be wired. Attach conduit to the back box as required using knockouts provided. It is recommended that input circuit wiring be physically separated from output circuit wiring.
- Have the Unit inspected before applying power. Correct and re-inspect any problems found.
- Turn on the AC power to Unit. If no problems occur other than Low Battery, attach the batteries to the wires provided, the black wire to the black (negative) terminal and the red wire to the red (positive) terminal. If the batteries need charging, the Low Battery condition remains until they are charged.



Note: For Canadian installations in a network environment, a LED annunciator is required mounted next to the Master Panel.

Use MR-2944-ANN chassis mounted in one of the following boxes as required:

- MR-2944-BBS annunciator enclosure for four strips
- MR-2944-BBL annunciator enclosure for eight strips

Refer to LT-2020 MR-2944 Installation Manual for detailed installation information.

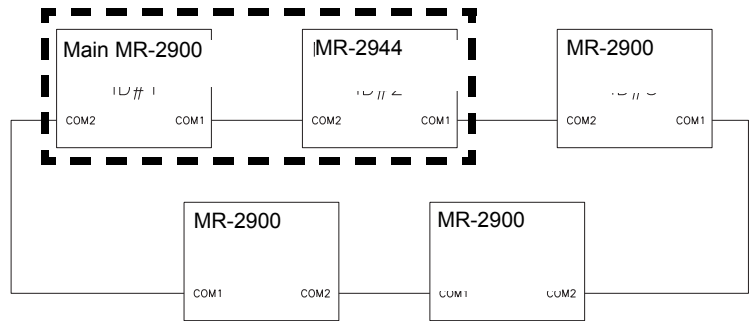

Figure 3: MR-2900 and MR-2944 in a Network



Note: The MR-2944 must be physically located next to the Main MR-2900 Panel.

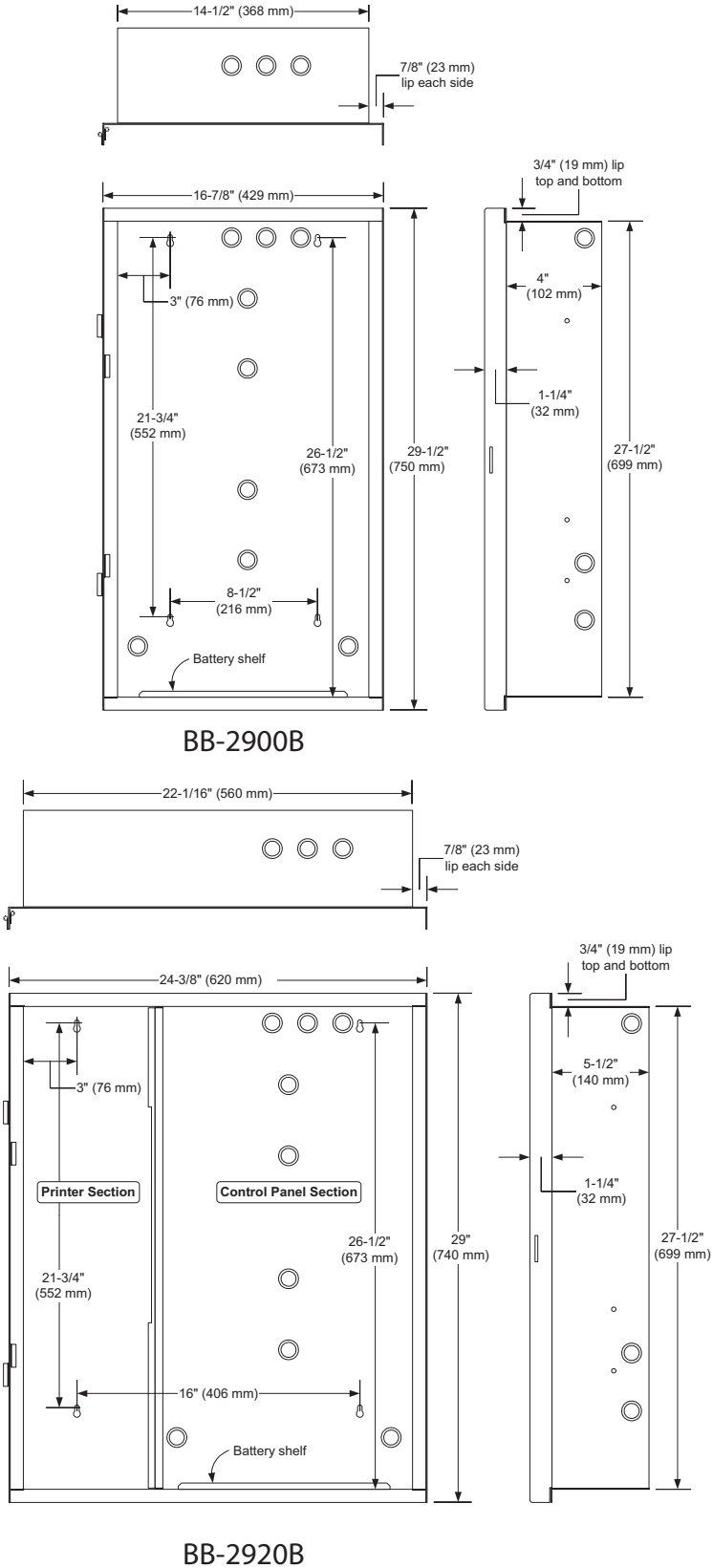

Figure 4: Back Box Dimension and Knockout Reference

2.4 Wiring

Power Connections

The Main Control Unit requires an AC power supply. See Figures 5 and 6 below.

The batteries forming the Battery Pack are wired in series. The Battery Pack attaches to the two wires coming from the Power Supply Board, the black wire to the black (negative) terminal and the red wire to the red (positive) terminal. The internal batteries are not used when an external battery box is used. The wires for connecting the power supply board to the batteries are supplied with the panel if a battery box is ordered at the same time.

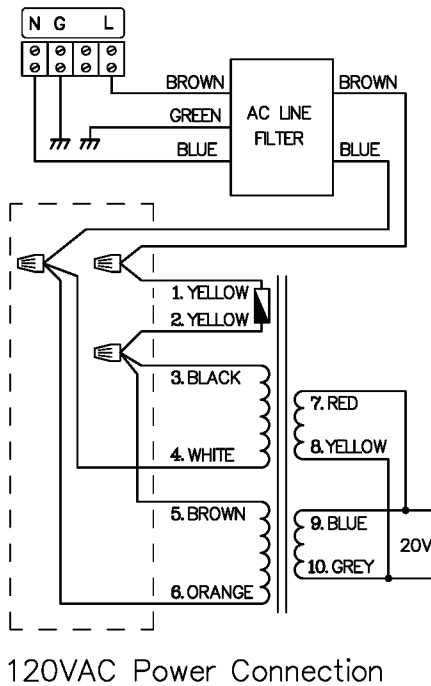

120VAC Power Connection

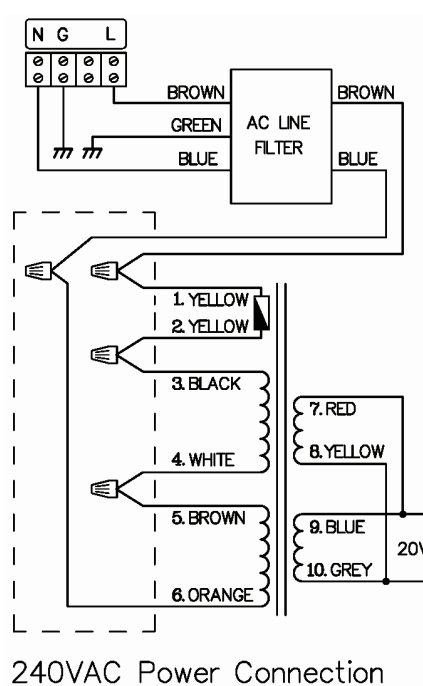

240VAC Power Connection

Figure 5: 120VAC Power Connection

Figure 6: 240VAC Power Connection



Warning: Never connect or disconnect the batteries while the AC power is off.

Conventional Style B (Class B) Circuit

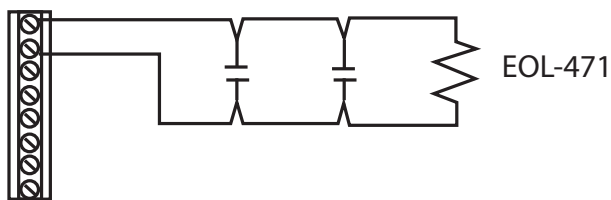

Figure 7: Conventional Style B (Class B) Wiring

This is a 2-wire power-limited and supervised Style B (Class B) initiating device circuit using conventional normally open contact devices and an end-of-line resistor, supported by the MR-2928 smoke and contact module. Maximum wire lengths are shown in Table 2. The end-of-line resistor is a 470Ω resistor EOL-471. Devices and the end-of-line resistor are connected as illustrated in Figure 7.



Note: 2-wire smoke detectors cannot be used on this type of circuit. This circuit may be wired on any of the 24 input circuits on the MR-2900 terminal boards.

Conventional Style D (Class A) Circuit

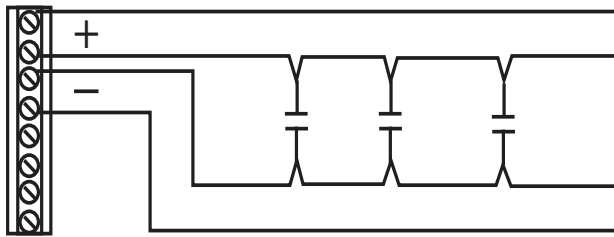

Figure 8: Conventional Style A (Class A) Wiring

This is a 4-wire power-limited and supervised Style D (Class A) initiating device circuit using conventional normally open contact devices. It is supported by the MR-2928 module. Maximum wire loop lengths are shown in Table 2. Devices are connected as illustrated in Figure 8. The return wiring must be in a separate conduit.



Note: 2-wire smoke detectors cannot be used on this type of circuit. This circuit may be wired on any of the 24 input circuits on the MR-2900 terminal boards.

Smoke Detector Circuits, Style B (Class B)

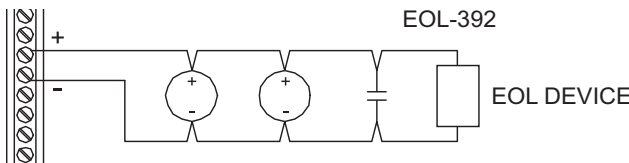

Figure 9: Smoke Detector Circuit Wiring, Style B (Class B) Wiring

This is a 2-wire power-limited and supervised Class B (Style B) initiating device circuit using 2-wire smoke detectors, conventional normally open contact devices (optional) and a end-of-line device. Maximum wire lengths are shown in Table 2. The end-of-line device is EOL-392 resistor. Detectors and the end-of-line device are connected as illustrated in Figure 9. Use only smoke detectors that are listed for compatibility.



Note: This circuit is supported by the MR-2928 Input Circuit Module. This circuit may be wired on any of the 24 input circuits on the MR-2900 terminal boards.

Smoke Detector Circuits, Style D (Class A)

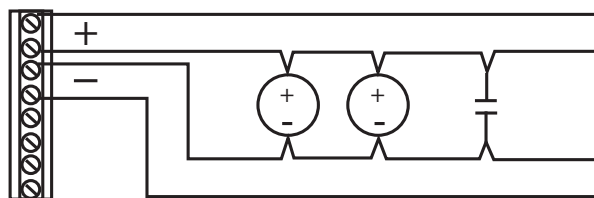

NOTE: WIRING REQUIRES
TWO CIRCUITS

Figure 10: Smoke Detector Circuit Wiring, Style D (Class A) Wiring

This is a 4-wire power-limited and supervised Style D (Class A) initiating device circuit using 2-wire smoke detectors and conventional normally open contact devices (optional). Maximum wire lengths are shown in Table 2. Detectors are connected as illustrated in Figure 10. Use only smoke detectors that are listed for compatibility. Return wiring must be in a separate conduit.



Note: This circuit is supported only by the MR-2938 Conventional "Class A" Input Circuit Module. This circuit may be wired on any of the 24 input circuits on the MR-2900 terminal boards.

Normally Closed Circuit

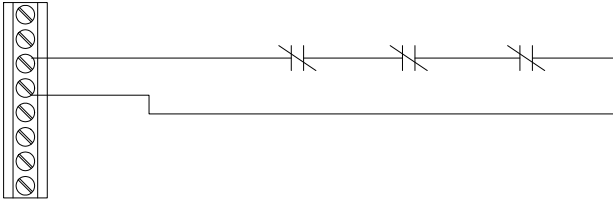

This is a 2-wire non-supervisory circuit and is supported by the MR-2928 module. This circuit is listed by UL for connection to other control equipment through less than 20 feet of conduit. Devices are connected as illustrated in Figure 11. Maximum wire lengths are shown in Table 2.

Figure 11: Normally Closed Wiring

Notes:

- This circuit shall not be used to monitor fire alarm or supervisory initiating devices. This circuit may be wired on any of the 24 input circuits on the MR-2900 terminal boards.
- All distances refer to total wire length.

Normally Open Circuit

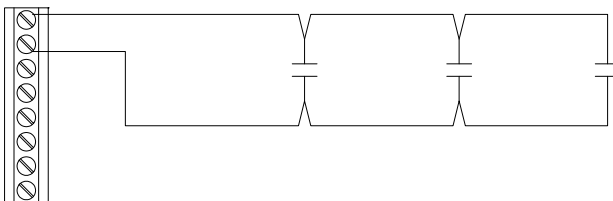

This is a 2-wire supervisory circuit. It is supported by the MR-2928 module. This circuit is listed by UL for connection to other control equipment through less than 20 feet of conduit. Devices are connected as illustrated in Figure 12. Maximum wire lengths are shown in Table 2.

Figure 12: Normally Open Wiring

Note: No fire alarm initiating devices can be connected to this class of circuit. This circuit may be wired on any of the 24 input circuits on the MR-2900 terminal boards.

Table 2: Maximum Wire Lengths for Conventional Input Circuits

AWG	Length
14	7 620m (25 000 ft)
16	4 846m (15 900 ft)
18	3048m (10 000 ft)
22	1524m (5 000 ft)

Addressable Style 4 (Class B) Circuit

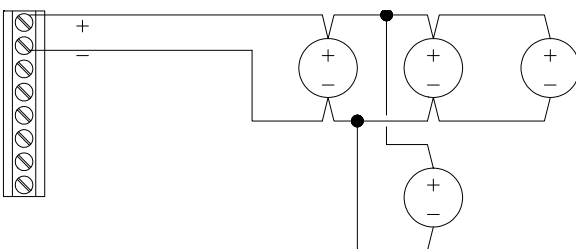

This is a 2-wire power-limited and supervised Style 4 (Class B) communications circuit using addressable devices. It requires the use of the MR-2929 or MR-2909 module. Wire capacitance and resistance affects the allowable wire length. The recommended wiring is twisted unshielded pair. Consult Secutron's Applications Department for specific requirements. Maximum wire lengths are up to 10,000 ft (see Table 3). Devices are connected as illustrated in Figure 13. Use only approved devices.

Figure 13: Addressable Style 4(Class B) Wiring



Note: T-taps may NOT be allowed by the authority having jurisdiction. Refer to NFPA 72 and ULC-S524. This circuit may be wired on any input circuit from 9 to 24 on the MR-2900 terminal boards.

Addressable Style 6 (Class A) Circuit

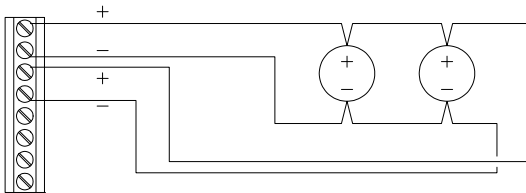

NOTE: WIRING REQUIRES TWO CIRCUITS

Figure 14: Addressable Style 6 (Class A) Wiring

This is a 4-wire power-limited and supervised Style 6 (Class A) communications circuit using addressable devices. It requires the use of the MR-2929 or MR-2919 module. Maximum wire loop lengths are up to 10 000 ft (see Table 3). The recommended wiring is twisted unshielded pair. Wire capacitance and resistance affects the allowable wire length. Consult Secutron's Applications Department for specific requirements. Devices are connected as illustrated in Figure 14. Use only approved devices. Return wiring must be in a separate conduit. When using isolators, it is necessary to put an isolator between panel terminal blocks and the device.



Notes:

- All distances refer to total wire length.
- This circuit may be wired on any input circuit from 9 to 24 on the MR-2900 terminal boards.

Table 3: Maximum Wiring Length for Addressable Circuits

Gauge	Belden No.	Distance
12	9582	3 048m (10 000 ft)
14	9580	2 438m (8 000 ft)
16	9572	1 402m (4 600 ft)
18	9571	975m (3 200 ft)

Addressable Modules

The addressable module extended circuits are wired as shown on the next page in Figures 15 - 20.

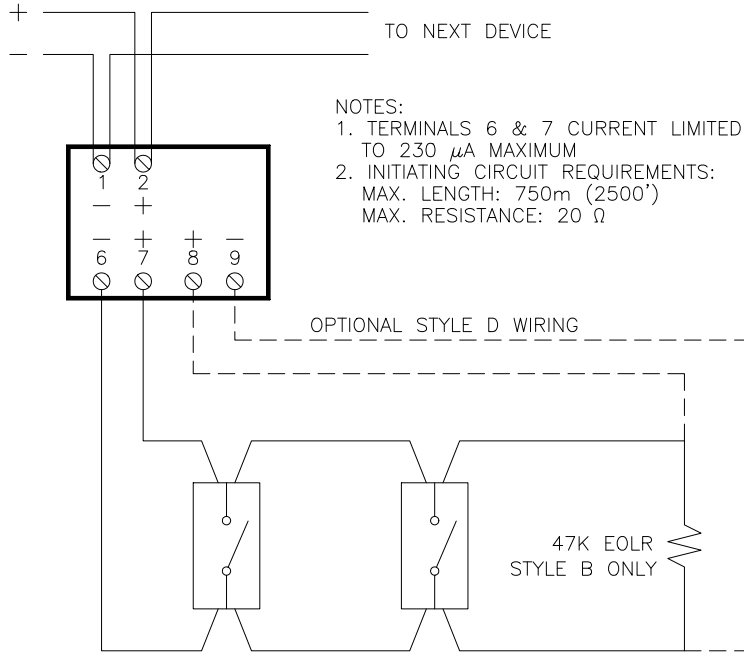
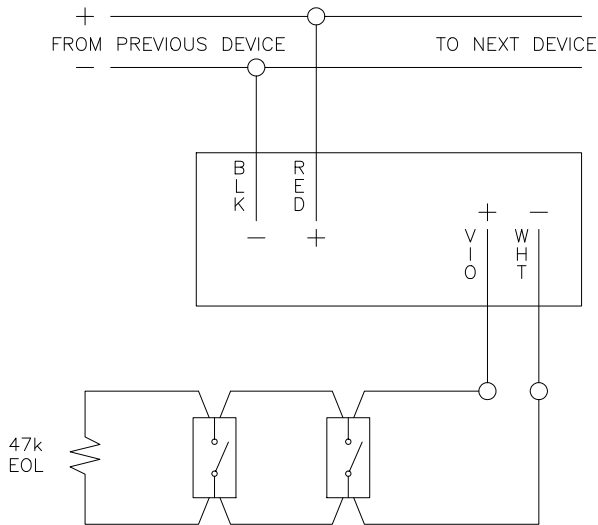

Figure 15: MRI-M500M Wiring



- NOTES:
 1. TERMINALS 6 & 7 CURRENT LIMITED TO 230 μ A MAXIMUM
 2. INITIATING CIRCUIT REQUIREMENTS:
 MAX. LENGTH: 750m (2500')
 MAX. RESISTANCE: 20 Ω

Figure 16: MRI-M501 Wiring

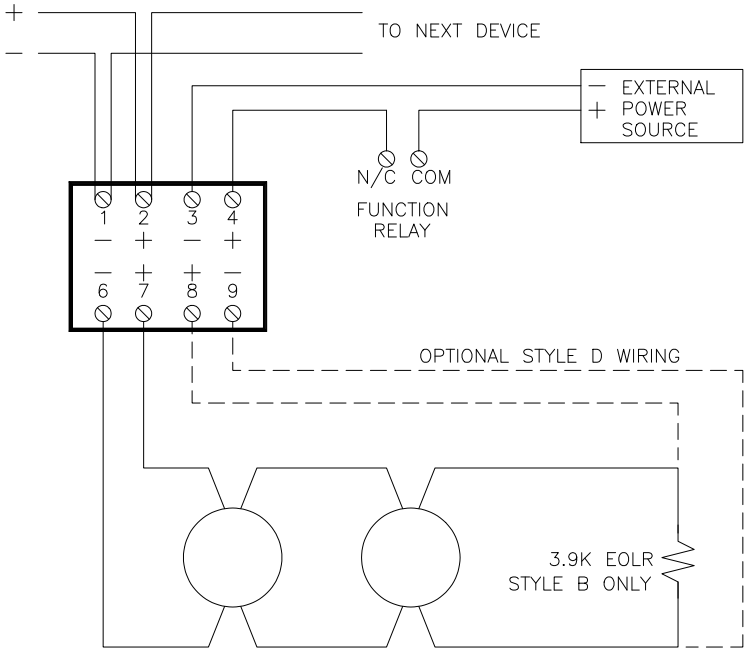

Figure 17: MRI-M502M Wiring

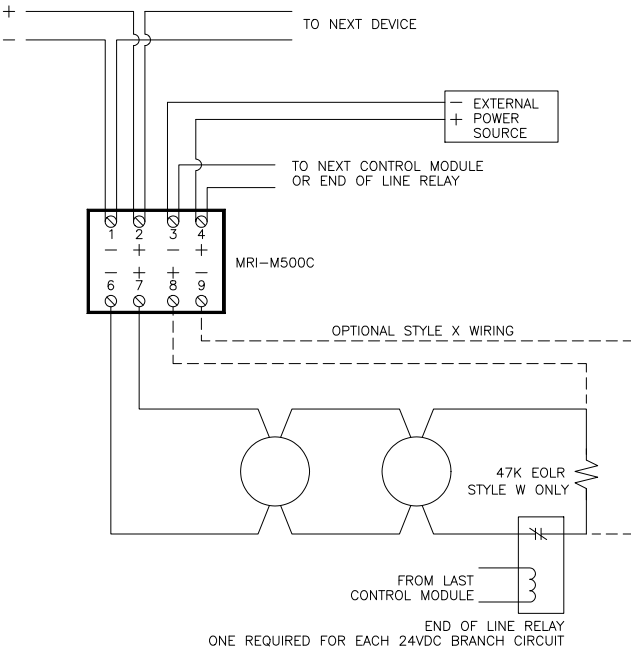
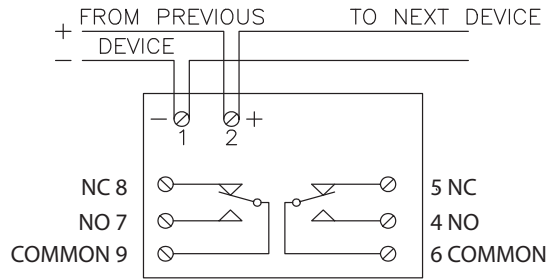

Figure 18: MRI-M500S Wiring for Signalling Circuits



RELAY CONTACT RATINGS:
 RESISTIVE: 2A, 30VDC
 INDUCTIVE: 1A, 30VDC (0.6 PF)
 0.3A, 110VDC (0.35 PF)
 0.3A, 120VAC (0.35 PF)

NOTE: 1A, 30VDC RATING DOES NOT APPLY FOR PILOT DUTY OR MOTOR LOADS.

Figure 19: MRI-M500R Wiring for Form C Relay Use

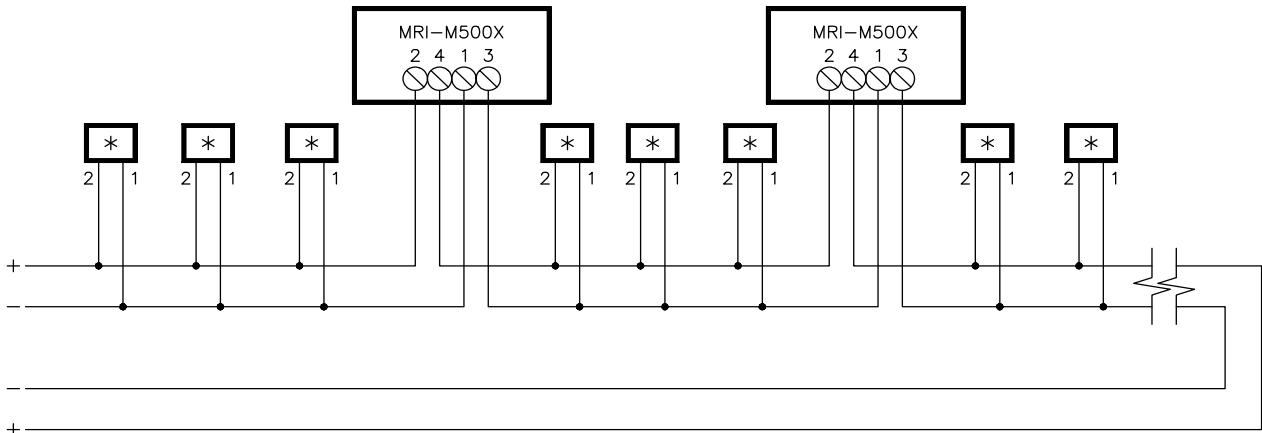

*ANY COMBINATION OF MRI DEVICES MAY BE USED

Figure 20: MRI-M500X Wiring

Style Y (Class B) Bell Circuit

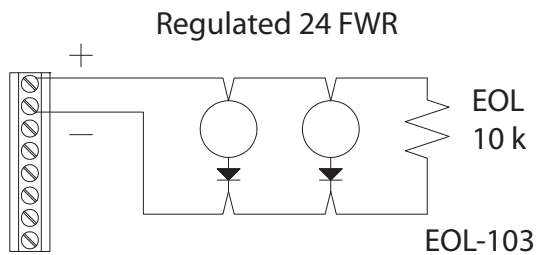

Figure 21: Style Y (Class B) Bell Circuit Wiring

This is a 2-wire Style Y (Class B) power-limited and supervised signalling (notification appliance) circuit. Devices and the 10 k end-of-line resistor are connected as illustrated in Figure 21. Maximum wire lengths are shown in Table 4. Use only approved devices.



Note: The inrush current of some devices may cause the current to exceed the 1.5A current limit momentarily.

Style Z (Class A) Bell Circuit

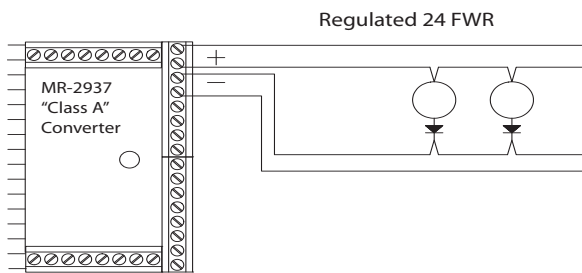

This is a 4-wire Style Z (Class A) power-limited and supervised signalling (notification appliance) circuit. Devices are connected as illustrated in Figure 22. Maximum wire lengths are shown in Table 4. This is for the total length of wire, from the panel to furthest device and back to the panel. Use only approved devices. Return wiring must be in a separate conduit.

Figure 22: Style Z (Class A) Bell Circuit Wiring



Note: The inrush current of some devices may cause the current to exceed the 1.5A current limit momentarily.

Table 4: Maximum Wire Lengths for Bell Circuits

	250 mA	500 mA	750 mA	1.0 A	1.25 A	1.50 A
12 AWG	1220m (4000 ft)	610m (2000 ft)	407m (1300 ft)	305m (1000 ft)	244m (800ft)	203m (667ft)
14 AWG	732m (2400 ft)	366m (1200 ft)	244m (800 ft)	183m (600 ft)	146m (480ft)	122m (400ft)
16 AWG	457m (1500 ft)	229m (750 ft)	152m (500 ft)	114m (375 ft)	91m (300ft)	76m (250ft)

Relay Connections

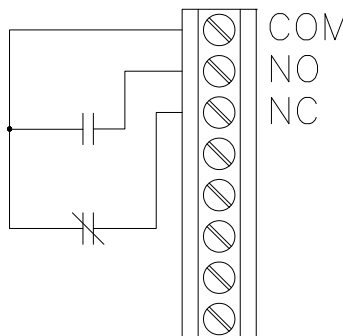

Unused relays are left unconnected. General Purpose Relays and System Relays operate identically and are wired the same (see Figure 23).

All relay wiring is unsupervised. The general purpose relays (Function Relays 1-4) have a power factor of .35, power-limited at .6A @ 30VAC/2.0A @ 30VDC. The Alarm, Supervisory, and Trouble relays have a power factor of .35, power-limited at .5A @ 30VAC/1.0A @ 24VDC.

Figure 23: Relay

Auxiliary Power Circuits

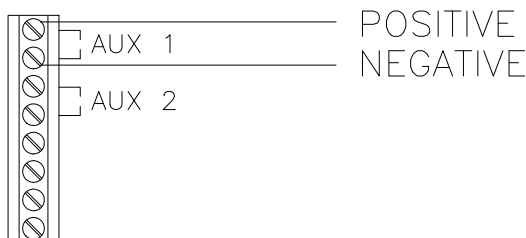

The auxiliary power circuits provide 24 VDC for external devices. The polarity of the circuits is shown in Figure 24. The Control Unit does not interrupt this circuit. For the wiring to be power-limited and supervised an end-of-line relay (Part number PAM-3) must be used. The relay is a 24VDC coil with 3A contacts.

Figure 24 Auxiliary Power Connections

Inner Door Ribbon Cables

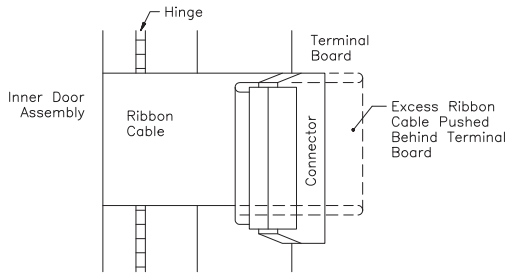

Two ribbon cables connect the Terminal Board to the Main Circuit Board. These cables are on the hinged side of the Inner Door and are long enough that the Inner Door can be fully opened without removing the cables. Ensure that the cables are not twisted and is seated properly in the connectors. These cables must be attached before the unit is powered (see Figure 25).

Figure 25: Ribbon Cable Installation



Note: Inserting or removing the ribbon cables while the unit is powered can result in damage to the unit.

Standard Network Wiring



Figure 26: Standard Network Wiring

Standard Network wiring uses a twisted pair of wires between each panel (see Figure 26). The COM1 of each Unit is connected to the COM2 of the next Unit. MR-2944 Annunciator Unit are connected the same as the Control Unit. Wiring is not polarity sensitive. Network wiring is power-limited. Only COMLINK 1 is supervised for ground faults.

COMLINK 2 is supervised for ground faults through its connection to COMLINK1 of previous attached panel.



Note:

- Ensure that only one COM2 is connected to each COM1. If two or more are connected, the network segment does not work.
- The following table shows the maximum wiring capacitance for the various baud rates supported by the Network using the standard MR-2910. The maximum allowable line resistance is 680 ohms.

Table 5: Maximum Capacitance for Network Baud Rates

Baud Rate	Maximum Capacitance	Maximum Network Nodes
9600	100 nF	254
4800	220 nF	254
2400	470 nF	254
1200	680 nF	200

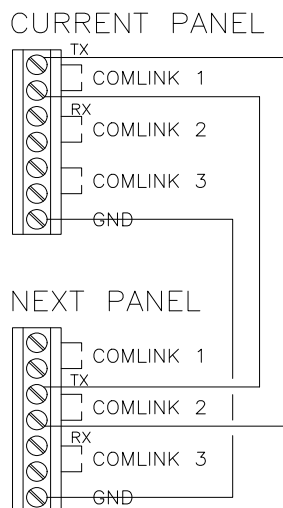
RS-232 Network Wiring

RS-232 Network wiring uses three (3) wires between each panel (see Figure 27). The COM1 of each Unit is connected to the COM2 of the next Unit. MR-2944 Annunciator Units are connected the same as the Control Unit. Wiring is polarity sensitive.

Figure 27: RS-232 Network Wiring**Notes:**

- Ensure that only one COM 2 is connected to each COM 1. If two or more are connected, the network segment does not work.
- The wire length limit for RS-232 is 20 feet (6m) in conduit, in the same room. For systems using modems, this is the maximum distance between the panel and the modem.

MR-D1010R Wiring

Refer to *LT-2048 MR-D1010R Fiber Optic Module Installation Instructions*.

Annunciator, UDACT and Reverse Polarity Wiring

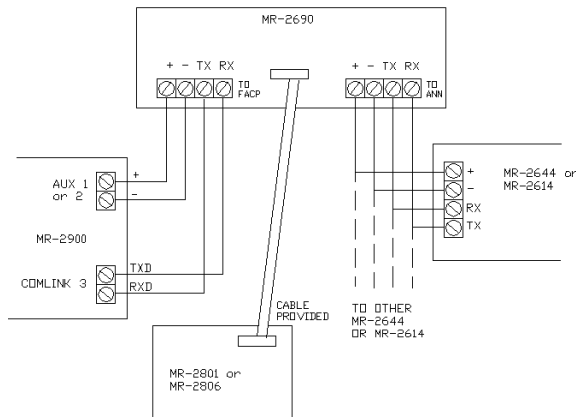

Figure 28: MR-2614, MR-2644, MR-2900-DACT and MR-2900-CITY Wiring

The MR-2614 and MR-2644 Annunciators, the MR-2900-CITY Reverse Polarity module and the MR-2900-DACT Dialer are connected to COMLINK 3 of the panel by 4 wires; 2 for power and 2 for communications. The communications wiring is polarity sensitive. An example of the wiring is shown in Figure 28. Up to eight of each type of annunciator and either one dialer or one reverse polarity module can be connected to the MR-2900. If more than one MR-2614 is used, the 3.9kΩ resistor across the MR-2614 terminals should be removed from all but the last MR-2614. The MR-2900 panel requires that the MR-2109-3 communications board be installed. The maximum length of communications wiring is 900m (3000 ft) using 22 AWG. The maximum length of power wiring is 300m (1000 ft) using 18 AWG.

Evax System Wiring

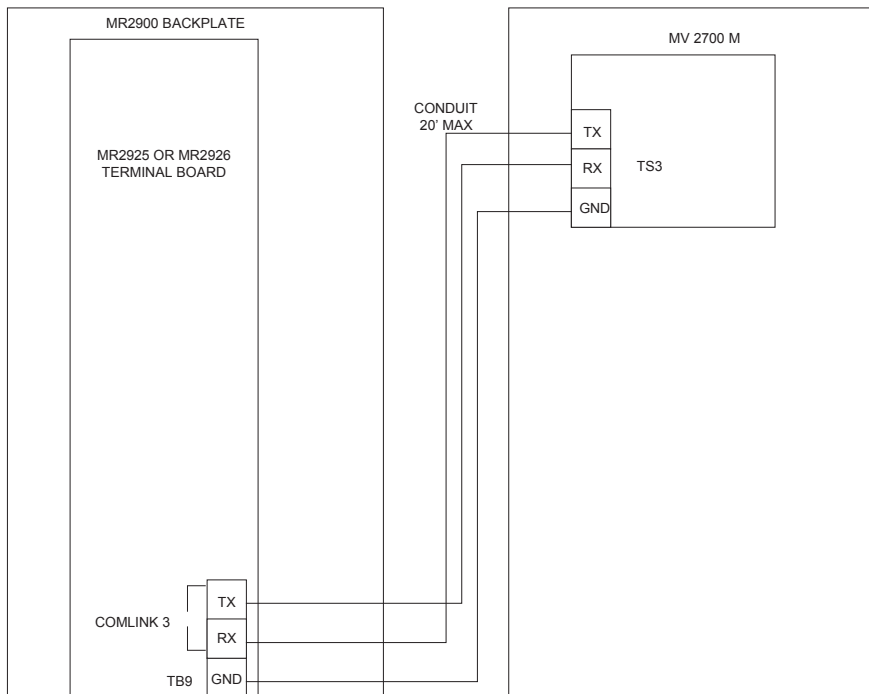

Figure 29: EVAX System Wiring

****The MR-2900 panel requires the use of the MR-2109-4 board.**

Notes:

- For all EVAX installations, the maximum wiring distance from the FACP to the HMX panel is 20 feet in conduit. The two panels must be in the same room.
- MV-2700M and MV-2700D are not ULC listed.
- MV-2700M must be connected to an MV-2700D. The MV-2700M (M = Master) generates the audio signals. The MV-2700D (D = Distributed) distributes the audio signal via NACs.
- For information on connecting an MV-2700M to an MV-2700D, refer to those modules installation instructions.
- Devices connected to COMLINK 3 are to be installed close nipped.

3.0 Technical Specifications

Electrical Ratings

AC Line Voltage	120 V, 60 Hz / 240 V, 50 Hz 2A / 1A
AC Brownout@120V @240V	90 VAC NSC / 93 VAC Alarm 180 VAC NSC / 186 VAC Alarm
Battery	24 Volt Sealed lead acid, up to 52 AHR
Current Consumption	500 mA in standby 8 Amps Max. in alarm

Compliance

System Model: MR-2900 Series Fire Alarm Control Panel

System Type: Local, auxiliary (using MR-2900-CITY), remote protected premise station (using MR-2900-CITY or MR-2900-DACT), central station protected premises (using MR-2900-DACT).

Type of Service: A, M, WF, SS (with MR-2900-CITY or MR-2900-DACT)

Type of Signalling: Non-coded

Applicable Standards: NFPA 70 and 72, UL-864 Rev.9, ULC S-524, ULC S-527-99 Input (Initiating Device) Circuits (24)

	Conventional	Addressable
Voltage	24 VDC	24 VDC
Ripple Voltage	2 V p-p	N.A.
Supervisory Current		
Contact Devices	5 mA	N.A.
Smoke Detectors	10 mA	N.A.
Alarm Current		
Contact Devices	10 mA	N.A.
Smoke Detectors	80 mA	N.A.
Max. No. of Devices	25 (Smoke Detectors)	99 Detectors / 99 Modules
Compatible Devices	MR Series	MR Series
Note: Consult 6.0 Appendix B: ULC Listed Compatible Smoke Detectors on page 28 or 7.0 Appendix C: UL Listed Compatible Devices on page 31		
End of Line Device		
Contact Circuit	470Ω Resistor (EOL-471)	N.A.
Smoke Detectors	EOL-392	N.A.
Total Line Resistance	200Ω	40Ω
Total Line Capacitance	100 uF	0.5 uF
Total Line Length	See Table 2	See Table 3
T-Tapping	No	Class B (Style 4) Only

Bell (Notification Appliance) Circuits

Number & Type	8 Class B, NFPA Style Y/ Class A, NFPA Style Z
Supervisory Current	1.0 mA, power limited
Alarm Current	1.5 A, power limited (NAC/1.0 A, power limited, Releasing)
Voltage	24 VDC, nominal, full wave rectified, unfiltered
End of Line Device	Class B (Style Y) only: 10 KΩ Resistor, EOL-103

Note: Consult Appendix C UL Listed Compatible Devices

System Relays (3)

Type	Form C, one each for Alarm, Supervisory and Trouble
Rating	0.5 A @ 30VAC (resistive) / 1.0A @ 24VDC

Note: These relays are not listed by UL for use for connection to equipment outside the same room as the Control Panel.

General Purpose Relays (4)

Type	Form C
Rating	0.6A @ 30VAC (resistive) / 2.0A @ 30VDC

Auxiliary Power Outputs (2)

Voltage	24 VDC
Ripple Voltage	2 Vrms, maximum
Current	135 mA per circuit, power limited

Notes:

- Consult Appendix C UL Listed Compatible Devices
- If load exceed 135mA, any NAC output circuit can be programmed as Aux power to provide up to 1.5 A.

MR-2910 Network Communication Boards

MR-2910	Network Communication Module, Both Ports Standard
MR-2910-R1	Network Communication Module, Port 1 RS-232, Port 2 Standard
MR-2910-R2	Network Communication Module, Port 1 Standard, Port 2 RS-232
MR-2910-R12	Network Communication Module, Both Ports RS-232

	Standard	RS-232
Wire Type	Twisted Pair	Twisted Pair
Gauge	18-22 AWG	18-22 AWG
Distance	*10 km (apr. 6 miles)	Under 6m (20 ft)
Application	Direct Wire	Fiber Optic Modem

*Using 22 AWG wire.

Battery Boxes

Model	Capacity	Size
MR-2978B	24-52 Ah	21" x 9" x 7" white
MR-2978R	24-52 Ah	21" x 9" x 7" red

4.0 Parts List

Model	Description
Basic Control Unit	
MR-2900	Basic Control Unit (with or without MR-2920 strip printer)
Optional Modules	
MR-2928	Conventional Input Circuit Module, 8 Circuit, Software Selectable for 10 or 80 mA, smoke and contact circuits
MR-2938	Conventional Input Circuit Module, 4 Circuit, "Class A", 80 mA, smoke and contact circuits
MR-2929	Addressable Input Circuit Module, 8 Circuit, "Class B" / 4 Circuit, "Class A"
MR-2909	Addressable Input Circuit Module, 8 Circuit, "Class B"
MR-2919	Addressable Input Circuit Module, 4 Circuit, "Class A"
MR-2910	Network Communication Module, Both Ports Standard
MR-2910-R1	Network Communication Module, Port 1 RS-232, Port 2 Standard
MR-2910-R2	Network Communication Module, Port 1 Standard, Port 2 RS-232
MR-2910-R12	Network Communication Module, Both Ports RS-232
MR-2109-3	Port 3 Communications Board for connection to MR-2614, MR-2644, MR-2900-DACT and MR-2900-CITY
MR-D1010R1	Fiber Optic Module, One Modem
MR-D1010R2	Fiber Optic Module, Two Modem
Annunciators	
MR-2944	Annunciator Driver
MR-2944LCD	Annunciator Driver c/w 80 Character LCD
MR-2614	LED Annunciator
MR-2614EH	Enhanced LED Annunciator
MR-2644	LCD Annunciator
MR-2915	LED Driver for Annunciators
MR-2902	Annunciator Strip, 3 x 24 LEDs
MR-2622	Annunciator Strip, 3 x 8 LEDs
Accessories	
MHI	Modul-R Human Interface database editor
EOL-471	470 Ω End-of-Line Resistor for conventional contact circuits
EOL-103	10k Ω End-of-Line Resistor for bell circuits
ELRX-300(W/R)	Plate for End-of-Line Resistor
EOL-392	End-of-Line Device for conventional smoke circuits
Replacement Modules - Consult the factory	
Hardware	
MR-2978(B/R)	Battery Box for 17 and 24 AHr batteries c/w cables, 21" W x 9" H x 7" D
BA-104	4.0 AHr Battery
BA-1065	7.0 AHr Battery
BA-110	10 AHr Battery
BA-117	17 AHr Battery
BA-124	24 AHr Battery

5.0 Appendix A: Power Supply and Battery Calculations

IMPORTANT NOTICE

The main AC branch circuit connection for Fire Alarm Control Panel must provide a dedicated continuous power without provision of any disconnect devices. Use #12 AWG wire with 600-volt insulation and proper over-current circuit protection that complies with the local codes. Refer to 3.0 *Technical Specifications* on page 23 for specifications.

POWER REQUIREMENTS (ALL CURRENTS ARE IN AMPERES)

Model Number	Description	Qty		Standby	Total Standby	Alarm	Total Alarm
MR-2900	Fire Alarm Control Unit (includes MR-2931, MR-2905, MR-2902)		X	0.092	=	0.107	=
MR-2900 Unique LED's			X	0.005	=	n/a	=
MR-2910	Network Communication Module		X	0.005	=	0.005	=
MR-2938	Conventional Input Circuit Module		X	0.018	=	0.101	=
MR-2929	Addressable Input Circuit Module		X	0.050	=	0.050	=
MR-2909	Addressable Input Circuit Module		X	0.001	=	0.001	=
MR-2928	Conventional Input Circuit Module		X	0.014	=	0.094	=
MR-2919	Addressable Input Circuit Module		X	0.005	=	0.005	=
MR-2614	LED Annunciator		X	0.020	=	0.155	=
MR-2622	Annunciator Strip		X	0.005	=	0.125	=
MR-2644	LCD Annunciator		X	0.030	=	0.070	=
MR-2900-CITY	City Card		X	0.020	=	0.315 (reverse polarity mode) 0.035 (in alarm (+ load - 65mA for 3 circuits))	=
MR-2900-DACT	Digital Communication Module		X	0.040	=	0.060	=
MR-2109-3	Digiquad Module		X	0.008	=	0.0008	=
MR-2944	Annunciator		X	0.075	=	0.075	=
MR-2915	LED Driver Card		X	0.001	=	0.010	=
MR-2920	Strip Printer		X	0.125	=	0.800 when printing	=
MR-D1010-R1	Fibre Optic Modem		X	0.075	=		=
MR-D1010-R2	Fibre Optic Modem		X	0.150	=		=
MR-2690	Isolation Module		X	0.010	=		=
Two-Wire Smoke Detectors			X	§	=		=
Four-Wire Smoke Detectors			X	§	=		=
Signal Load (bells, horns, strobes, and etc.)			X	§	=		=
Auxiliary Power Supply for Annunciators, etc.					=		=
Total currents (Add above currents)				STANDBY	(A)	ALARM	(B)

* See 6.0 Appendix B: ULC Listed Compatible Smoke Detectors on page 28 and 7.0 Appendix C: UL Listed Compatible Devices on page 31 for other compatible devices.

Total Current Requirement: ALARM (B) _____ Amps. (Value obtained from column B)

Battery Capacity Requirement:

$$\text{Battery (AH)} = ([\text{STANDBY (A)} \text{ _____}] \times [(24,60 \text{ or } 90 \text{ Hours}) \text{ _____}]) + ([\text{ALARM (B)} \text{ _____}] \times [\text{Alarm in Hr.}] \text{ _____}) = \text{(C)} \text{ _____ AH}$$

Battery Selection: Multiply (C) by 1.20 to derate battery.

5.1 General

Batteries are designed and manufactured for a specific use. "Standby" is one of these uses. They are rated according to their ability to deliver a steady current for 20 hours ("20 Hour Rating"). A 10 Ah battery is unable to deliver 10 A for 1 hour, however it does deliver ½ A (500 mA) for 20 hours. A car battery is designed to deliver "cranking" power for a short time, (a few hundred Amps for a few minutes). Unfortunately, fire alarm control panels need both of these characteristics, that is, driving a heavy bell load for a relatively short time, at the end of a 24 hour standby current drain. This protection necessitates certain over sizing.

Regardless of the standby calculation and tables, the battery must be at least 150% of the bell load. e.g. A 4 A total bell load necessitates at least 6 A hour battery (in terms of 20 hour rating).



Note: The MR-2900 Control Panel is capable of driving a bell load of 8 A maximum. This restriction must be considered when laying out a bell system..

The standard battery options available for the MR-2900 Control Unit are:

- a) 4 AHr internal
- b) 7 AHr internal
- c) 10 AHr internal
- d) 17 AHr external in a separate battery cabinet
- e) 24 AHr external in a separate battery cabinet
- f) 52 AHr external in a separate battery cabinet

6.0 Appendix B: ULC Listed Compatible Smoke Detectors

The following conventional smoke detectors are ULC listed for compatibility with the MR-2900 Control Panel using Conventional Circuit Input Modules

Make & Model	# of Devices /Circuit	Make & Model	# of Devices /Circuit
Hochiki		Mirtone	
DCD-135/NS6-220	30	73471	30
DCD-135/NS4-220	30	73494	100
DCD-135/HSC-220R	30	73575	60
DCD-190/NS6-220	30	73495/73486	100
DCD-190/NS4-220	30	73495/73487	100
DCD-190/HSC-220R	30	73595/73486	60
SIJ-24/NS6-220	30	73595/73497	60
SIJ-24/NS4-220	30	73594/73400	60
SIJ-24/HSC-220R	30	73405/73400	100
SLR-24/NS6-220	30	73594/73401	60
SLR-24/NS4-220	30	73405/73401	100
SLR-24/HSC-220R	30	System Sensor	
SLR-24H/NS6-220	30	1400-A	30
SLR-24H/NS4-220	30	2400-A	25
SLR-24H/HSC-220R	30	1451-A/B401B	25
SLR-835/NS6-220	30	1451-A/B406B	25
SLR-835/NS4-220	30	2451-A/B401B	25
SLR-835/HSC-220R	30	2451-A/B406B	25
SLR-835B-2	30	1451DH/DH400A	30
Cerebrus Pyrotronics		2451-A/DH400A	25
D1-2		1151A	30
D1-3/DB-3S	30	2151A	30
Mircom		C2W-BA/C2WT-BA	30
MIR-525	30	C2WTR-B	1
MIR-525T	30	C2WTA-BA	1
MIR-1400A	30	NAPCO	
MIR-2400A	25	FW-2	30

Make & Model	# of Devices /Circuit	Make & Model	# of Devices /Circuit
Simplex		Fenwal	
2098-9110		PSD-7131/70-201000-001	42
Edwards		PSD-7131/70-201000-002	42
6249C	100	PSD-7131/70-201000-003	42
6250C	100	PSD-7131/70-201000-005	42
6264C	100	PSD-7130/70-201000-001	42
6266C	60	PSD-7130/70-201000-002	42
6269C	60	PSD-7130/70-201000-003	42
6270C	60	PSD-7130/70-201000-005	42
6269C-003	60	PSD-7128/70-201000-001	42
6270C-003	60	PSD-7126/70-201000-002	42
Apollo		PSD-7126/70-201000-003	42
55000-325	30	PSD-7126/70-201000-005	42
55000-325 / 45681-251, -255, -256, -258	30	PSD-7129/70-201000-000	42
		PSD-7125/70-201000-001	42
		PSD-7126/70-201000-002	42
		PSD-7125/70-201000-003	42
		PSD-7125/70-201000-005	42
		CPD-7021/70-201000-001	42
		CPD-7021/70-201000-002	42
		CPD-7021/70-201000-003	42
		CPD-7021/70-201000-005	42

6.1 ULC Listed Compatible Addressable Devices

Model	Description	Typical Current Draw μ A
MRI-1251	Ionization type smoke detector	300
MRI-1251B	Ionization type smoke detector	300
MRI-2251	Photoelectric type smoke detector	300
MRI-2251B	Photoelectric type smoke detector	360
MRI-2251T	Photoelectric type smoke detector w/ thermal element	300
MRI-2251TB	Photoelectric type smoke detector w/ thermal element	360
MRI-2251TM	Acclimate Photo-Thermal Detector	300
MRI-2251TMB	Acclimate Photo-Thermal Detector	360
MRI-7251	Pinnacle™ Intelligent Laser Smoke Sensor	330
MRI-5251P	Thermal detector	200
MRI-5251B	Thermal detector	300
MRI-5251RP	Thermal detector w/ rate of rise	200
MRI-5251RB	Thermal detector w/ rate of rise	300
MRI-5251H	High Temperature Thermal detector	300
IM-10	10 Input Monitor Module	3.50 mA
CR-6	6 Relay Control Module	1.45 mA
SC-6	6 Supervised Control Module	2.25 mA
CZ-6	6 Zone Conventional Interface Module	2.00 mA
MRI-M500DM	Dual Input Monitor Module	300
MRI-M500M	Monitor module, Classes A/B initiating	300
MRI-M501M	Mini Monitor module, Class B initiating	300
MRI-M502M	Monitor Module for 2- wire smoke detectors Classes A/B initiating	200
MRI-M500S	Control module	300
MRI-M500R	Relay Module	300
MRI-M500X	Fault isolator module	450

7.0 Appendix C: UL Listed Compatible Devices

7.1 UL Listed “Class B” Smoke Detectors

The following Listed 2-wire smoke detectors and bases are compatible with the MR-2900 Control Panel using the MR-2928 Conventional Input Circuit Modules (with compatibility identifier MR-2928). Up to 5 μA of smoke detector normal standby load may be connected to MR-2928 conventional initiating device circuit.

Manufacturer	Smoke Detector Model	Base Identifier	Model	Standby Identifier	Current
System Sensor	1400	A	N/A	N/A	100 μA
	1451	A	B401	A	120 μA
	1451	A	B401B	A	120 μA
	2300T	A	N/A	N/A	120 μA
	2300TB	A	N/A	N/A	120 μA
	2400	A	N/A	N/A	120 μA
	2400TH	A	N/A	N/A	120 μA
	2451	A	B401	A	120 μA
	2451	A	B401B	A	120 μA
	2451	A	DH400	A	120 μA
	2451TH	A	B401	A	120 μA
	2451TH	A	B401B	A	120 μA
Apollo	55000-250	55000-250	45681-200	45681-200	59 μA
	55000-250	55000-250	45681-230	45681-230	80 μA
	55000-250	55000-250	45681-231	45681-231	80 μA
	55000-350	55000-350	45681-200	45681-200	110 μA
	55000-350	55000-350	45681-230	45681-230	130 μA
	55000-350	55000-350	45681-231	45681-231	130 μA
Cerebrus	DI-3C				
Pyrotronics	DI-4				
	DI-4B				
	PEC-3				
Detection Systems	DS200	A	MB200-2W	A	80 μA
	DS200HD	A	MB200-2W	A	80 μA
Edwards	6250B	001	6251B	001	30 μA
	6270B	001	6251B	001	50 μA

Manufacturer	Smoke Detector Model	Base Identifier	Model	Standby Identifier	Current	
Fenwal	CPD-7023	I3FE1	CPD-001	FE01A	80 μ A	
	CPD-7023	I3FE1	CPD-002	FE02A	80 μ A	
	CPD-7023	I3FE1	CPD-003	FE03A	80 μ A	
	CPD-7023	I3FE1	CPD-005	FE05A	80 μ A	
	CPD-7051	I3FE1	2-Wire	FE51A	60 μ A	
	CPD-7051	I3FE1	2WRLT	FE52A	60 μ A	
	CPD-7051	I3FE1	2WRB	FE53A	60 μ A	
	CPD-7051	I3FE1	CPD-001*	FE01A	60 μ A	
	CPD-7051	I3FE1	CPD-002*	FE02A	60 μ A	
	CPD-7051	I3FE1	CPD-003*	FE03A	60 μ A	
	CPD-7051	I3FE1	CPD-005*	FE05A	60 μ A	
	PSD-7134	P14FE1	CPD-001	FE01A	120 μ A	
	PSD-7134	P14FE1	CPD-002	FE02A	120 μ A	
	PSD-7134	P14FE1	CPD-003	FE03A	120 μ A	
	PSD-7134	P14FE1	CPD-005	FE05A	120 μ A	
	PSD-7135	P15FE1	CPD-001	FE01A	120 μ A	
	PSD-7135	P15FE1	CPD-002	FE02A	120 μ A	
	PSD-7135	P15FE1	CPD-003	FE03A	120 μ A	
	PSD-7135	P15FE1	CPD-005	FE05A	120 μ A	
	PSD-7155	P55FE1	2-Wire	FE51A	70 μ A	
	PSD-7155	P55FE1	2WRLT	FE52A	70 μ A	
	PSD-7155	P55FE1	2WRB	FE53A	70 μ A	
	PSD-7155	P55FE1	CPD-001*	FE01A	70 μ A	
	PSD-7155	P55FE1	CPD-002*	FE02A	70 μ A	
	PSD-7155	P55FE1	CPD-003*	FE03A	70 μ A	
	PSD-7155	P55FE1	CPD-005*	FE05A	70 μ A	
	PSD-7156	P56FE1	2-Wire	FE51A	70 μ A	
	PSD-7156	P56FE1	2WRLT	FE52A	70 μ A	
	PSD-7156	P56FE1	2WRB	FE53A	70 μ A	
	PSD-7156	P56FE1	CPD-001*	FE01A	70 μ A	
	PSD-7156	P56FE1	CPD-002*	FE02A	70 μ A	
	PSD-7156	P56FE1	CPD-003*	FE03A	70 μ A	
	PSD-7156	P56FE1	CPD-005*	FE05A	70 μ A	

* - Requires Fenwal MA-001 adapter with compatibility identifier MAFE.

Manufacturer	Smoke Detector Model	Base Identifier	Model	Standby Identifier	Current
Gentex	224	-1	N/A	N/A	
	224-25	-1	N/A	N/A	
Hochiki	SIF-24F	HD-2	HS-221D	HB-4	102 μ A
	SIF-24F	HD-2	YBA-M221	HB-4	102 μ A
	SIH-24F	HD-3	HS-221D	HB-4	130 μ A
	SIH-24F	HD-3	YBA-M221	HB-4	130 μ A
	SLK-24F	HD-3	HS-221D	HB-4	142 μ A
	SLK-24F	HD-3	YBA-M221	HB-4	142 μ A
	SLK-24FH	HD-3	HS-221D	HB-4	142 μ A
	SLK-24FH	HD-3	YBA-M221	HB-4	142 μ A

7.2 UL Listed “Class A” Smoke Detectors

The following Listed 2-wire smoke detectors and bases are compatible with the MR-2900 Control Panel using the MR-2938 Conventional Input Circuit Module with compatibility identifier as MR-2938. Up to 2.50 mA of smoke detector normal standby load may be connected to each MR-2938 conventional initiating device circuit.

Manufacturer	Smoke Detector Model	Base Identifier	Model	Standby Identifier	Current
System Sensor	1400	A	N/A	N/A	100 μ A
	1451	A	B401	A	120 μ A
	1451	A	B401B	A	120 μ A
	2400	A	N/A	N/A	120 μ A
	2400TH	A	N/A	N/A	120 μ A
	2451	A	B401	A	120 μ A
	2451	A	B401B	A	120 μ A
	2451	A	DH400	A	120 μ A
	2451TH	A	B401	A	120 μ A
	1451	A	B401BH	A	120 μ A
	2451	A	B401BH	A	120 μ A
	2451TH	A	B401BH	A	120 μ A
	4451TH	A	B401	A	120 μ A
	4451TH	A	B401B	A	120 μ A
	1151	A	B401BH	A	120 μ A
	1151	A	B116LP	A	120 μ A
	2151	A	B401	A	120 μ A
	2151	A	B401BH	A	120 μ A
	2151	A	B110LP	A	120 μ A
	2151	A	B116LP	A	120 μ A
	5451	A	B401	A	120 μ A
	5451	A	B401BH	A	120 μ A
	2100AT	A	N/A	N/A	100 μ A
	2100TR	A	N/A	N/A	100 μ A
	2W-B	A	N/A	N/A	100 μ A
	2WT-B	A	N/A	N/A	100 μ A

7.3 UL Listed Notification Appliances

The following notification appliances, where a current rating is shown, may be used with the MR-2900 Control Units.

Model	Type	Input Current at 24 VDC (in mA)	
		Audible	Visual
Wheelock			
MT-12/24-R	Multi tone Horn	48 (Hi), 26 (Lo)	-
MT-24-WH-VN-W	Multi tone Horn w/ Strobe, ADA	48 (Hi), 26 (Lo)	78
MT-24-WM-VF-R	Multi tone Horn w/ Strobe, ADA	48 (Hi), 26 (Lo)	96
EHS-DL1-W-VF-R	Electronic Strobe Horn, Single Input	35 (combined)	
EHS-EL1-W-VF-R	Electronic Strobe Horn, Single Input	35 (combined)	
EH-DL1-WS-24-VF-R	Electronic Strobe Horn, Dual Input	17	25
EH-EL1-WS-24-VF-R	Electronic Strobe Horn, Dual Input	17	25
EH-DL1-WH-24-VF-R	Electronic Strobe Horn, Dual Input	17	75
EH-EL1-WH-24-VF-R	Electronic Strobe Horn, Dual Input	17	75
EH-DL1-WM-24-VF-R	Electronic Strobe Horn, Dual Input	17	88
EH-EL1-WM-24-VF-R	Electronic Strobe Horn, Dual Input	17	88
AES-DL1-WS-24-VF-R	Multi tone Horn w/ Strobe	50 (Hi), 25 (Lo)	25
AES-EL1-WS-24-VF-R	Multi tone Horn w/ Strobe	50 (Hi), 25 (Lo)	25
AES-DL1-WH-24-VF-R	Multi tone Horn w/ Strobe	50 (Hi), 25 (Lo)	75
AES-EL1-WH-24-VF-R	Multi tone Horn w/ Strobe	50 (Hi), 25 (Lo)	75
AES-DL1-WM-24-VF-R	Multi tone Horn w/ Strobe	50 (Hi), 25 (Lo)	88
AES-EL1-WM-24-VF-R	Multi tone Horn w/ Strobe	50 (Hi), 25 (Lo)	88
WST-24-FR	Strobe	-	25
WS1T-24-FR	Strobe	-	25
WS3T-24-FR	Strobe	-	25
WHT-24-FR	Strobe	-	75
WH1T-24-FR	Strobe	-	75
WH3T-24-FR	Strobe	-	75
WMT-24-FR	Strobe	-	88
WM1T-24-FR	Strobe	-	88
WM3T-24-FR	Strobe	-	88
VLPM-24-W-VF-R	Strobe	-	88
7001T-24-W-FR	Strobe Horn	63 (combined)	
7002T-24-W-FR	Strobe Horn	63 (combined)	
V7001T-24-W-FR	Strobe Horn	63 (combined)	
MIZ-24-WS-VF-R	Mini-Horn w/ Strobe	40 (combined)	
MIZ-24-WS-VF-W	Mini-Horn w/ Strobe	40 (combined)	
MIZ-24-WH-VF-R	Mini-Horn w/ Strobe	90 (combined)	
MIZ-24-WM-VF-W	Mini-Horn w/ Strobe	103 (combined)	
CH-BF1-WS-24-HF-R	Strobe Chime	20	25

Model	Type	Input Current at 24 VDC (in mA)	
		Audible	Visual
CH-CF1-WS-24-CF-W	Strobe Chime	20	25
CH-DF1-WS-24-VF-R	Strobe Chime	20	25
CH-DF1-WM-24-VF-R	Strobe Chime	20	88
46T-G6-24-WS-24-HF-R	Strobe Bell, 6 in.	63	25
46T-G10-24-WS-24-HF-R	Strobe Bell, 10 in.	63	25
46T-G6-24-WH-24-HF-R	Strobe Bell, 6 in.	63	75
46T-G10-24-WH-24-HF-R	Strobe Bell, 10 in.	63	75
AS-2415W	Audible Strobe	92 (combined)	
AS-241575W	Audible Strobe	107 (combined)	
AS-2430W	Audible Strobe	126 (combined)	
AS-2475W	Audible Strobe	186 (combined)	
AS-24110W	Audible Strobe	213 (combined)	
AS-2415C	Audible Strobe	98 (combined)	
AS-2430C	Audible Strobe	133 (combined)	
AS-2475C	Audible Strobe	252 (combined)	
AS-24100C	Audible Strobe	283 (combined)	
NS-2415W	Strobe Horn	76 (combined)	
NS-241575W	Strobe Horn	90 (combined)	
NS-2430W	Strobe Horn	102 (combined)	
NS-2475W	Strobe Horn	163 (combined)	
NS-24110W	Strobe Horn	195 (combined)	
NS4-2415W	Strobe Horn	28	57
NS4-241575W	Strobe Horn	28	72
NS4-2430W	Strobe Horn	28	85
NS4-2475W	Strobe Horn	28	140
NS4-24110W	Strobe Horn	28	169
MT-24-LS	Multitone Strobe Signal, non sync	128 (combined)	
MT-24-LSM	Multitone Strobe Signal, non sync	163 (combined)	
MT-24-MS	Multitone Strobe Signal, non sync	183 (combined)	
MT-24-IS	Multitone Strobe Signal, non sync	273 (combined)	
MT-24-SL	Multitone Strobe Signal, sync	144 (combined)	
MT-24-SLM	Multitone Strobe Signal, sync	186 (combined)	
MT4-24-LS	Multitone Strobe Signal, non sync	48	80
MT4-24-LSM	Multitone Strobe Signal, non sync	48	115
MT4 -24- MS	Multitone Strobe Signal, non sync	48	135
MT4-24-IS	Multitone Strobe Signal, non sync	48	225
MT4-24-SL	Multitone Strobe Signal, sync	48	96
MT4-24-SLM	Multitone Strobe Signal, sync	48	138
AMT-24-LS	Multitone Strobe Signal, non sync	48	80

Model	Type	Input Current at 24 VDC (in mA)	
		Audible	Visual
AMT-24-LSM	Multitone Strobe Signal, non sync	48	115
AMT-24-MS	Multitone Strobe Signal, non sync	48	135
AMT-24-IS	Multitone Strobe Signal, non sync	48	225
AMT-24-SL	Multitone Strobe Signal, sync	48	96
AMT-24-SLM	Multitone Strobe Signal, sync	48	138
AMT4-24-LS	Multitone Strobe Signal, non sync	48	80
AMT4-24-LSM	Multitone Strobe Signal, non sync	48	115
AMT4-24-MS	Multitone Strobe Signal, non sync	48	135
AMT4-24-IS	Multitone Strobe Signal, non sync	48	225
AMT4-24-SL	Multitone Strobe Signal, sync	48	96
AMT4-24-SLM	Multitone Strobe Signal, sync	48	138
CH70-2415W	Strobe Chime	20	53
CH70-241575W	Strobe Chime	20	68
CH70-2430W	Strobe Chime	20	85
CH70-2475W	Strobe Chime	20	140
CH70-24110W	Strobe Chime	20	169
CH90-2415W	Strobe Chime	20	53
CH90-241575W	Strobe Chime	20	68
CH90-2430W	Strobe Chime	20	85
CH90-2475W	Strobe Chime	20	140
CH90-24110W	Strobe Chime	20	169
CH70-2415C	Strobe Chime	20	70
CH70-2430C	Strobe Chime	20	107
CH70-2475C	Strobe Chime	20	215
CH70-24100C	Strobe Chime	20	250
CH90-2415C	Strobe Chime	20	70
CH90-2430C	Strobe Chime	20	107
CH90-2475C	Strobe Chime	20	215
CH90-24100C	Strobe Chime	20	250
RSS-2415W	Strobe	-	53
RSS-241575W	Strobe	-	68
RSS-2430W	Strobe	-	85
RSS-2475W	Strobe	-	140
RSS-24110W	Strobe	-	169
RSSP-24110W	Strobe, retrofit plate	-	53
RSSP-241575W	Strobe, retrofit plate	-	68
RSSP-2430W	Strobe, retrofit plate	-	85
RSSP-2475W	Strobe, retrofit plate	-	140
RSSP-24110W	Strobe, retrofit plate	-	169

Model	Type	Input Current at 24 VDC (in mA)	
		Audible	Visual
RSS-2415C	Strobe	-	70
RSS-2430C	Strobe	-	107
RSS-2475C	Strobe	-	215
RSS-24100C	Strobe	-	250
RSSP-2415C	Strobe, retrofit plate	-	70
RSSP-2430C	Strobe, retrofit plate	-	107
RSSP-2475C	Strobe, retrofit plate	-	215
RSSP-24100C	Strobe, retrofit plate	-	250
SM -12/24	Sync Module	25 (combined)	
DSM -12/24	Dual Sync Module	38 (combined)	
Gentex			
GEH24	Commander2 Horn	21	-
GES24-15	Commander2 Strobe 15 cd	-	46
GES24-15/75	Commander2 Strobe 15/75cd	-	57
GES24-30	Commander2 Strobe 30 cd	-	57
GES24-60	Commander2 Strobe 60 cd	-	82
GES24-75	Commander2 Strobe 75 cd	-	89
GES24-110	Commander2 Strobe 110 cd	-	102
GEC24-15	Commander2 Horn/Strobe 15 cd	67 (combined)	
GEC24-15/75	Commander2 Horn/Strobe 15/75 cd	78 (combined)	
GEC24-30	Commander2 Horn/Strobe 30 cd	78 (combined)	
GEC24-60	Commander2 Horn/Strobe 60 cd	103 (combined)	
GEC24-75	Commander2 Horn/Strobe 75 cd	110 (combined)	
GEC24-110	Commander2 Horn/Strobe 110 cd	123 (combined)	
GMS24-15	Mechanical Horn/Strobe 15 cd	116 (combined)	
GMS24-15/75W	Mechanical Horn/Strobe 15/75 cd	131 (combined)	
GMS24-15/75C	Mechanical Horn/Strobe 15/75 cd	153 (combined)	
GMS24-15/75Z	Mechanical Horn/Strobe 15/75 cd	168 (combined)	
GMS24-30	Mechanical Horn/Strobe 30 cd	131 (combined)	
GMS24-30/75	Mechanical Horn/Strobe 30/75 cd	180 (combined)	
GMS24-60	Mechanical Horn/Strobe 60 Cd	153 (combined)	
GMS24-110	Mechanical Horn/Strobe 110 Cd	258 (combined)	
WGMS-4-75	Mechanical Horn/Strobe 75cd Weather	143 (combined)	
GX90S-4-15	Piezo Horn/Strobe 15 cd	93 (combined)	
GX90S-4-15/75W	Piezo Horn/Strobe 15/75 cd Wall	108 (combined)	
GX90S-4-15/75C	Piezo Horn/Strobe 15/75 cd Ceiling	130 (combined)	
GX90S-4-15/75Z	Piezo Horn/Strobe 15/75 cd Sync	145 (combined)	
GX90S-4-30	Piezo Horn/Strobe 30 cd	108 (combined)	
GX90S-4-30/75	Piezo Horn/Strobe 30/75 cd	157 (combined)	

Model	Type	Input Current at 24 VDC (in mA)	
		Audible	Visual
GX90S-4-60	Piezo Horn/Strobe 60 cd	130 (combined)	
GX90S-4-110	Piezo Horn/Strobe 110 cd	235 (combined)	
GXS-4-15	Strobe 15 Cd	-	78
GXS-4-15/75-W	Strobe 15/75 Cd Wall	-	93
GXS-4-15/75-C	Strobe 15/75 Cd Ceiling	-	115
GXS-4-15/75-Z	Strobe 15/75 Cd Sync	-	130
GXS-4-30	Strobe 30 Cd	-	93
GXS-4-30/75	Strobe 30/75 Cd	-	142
GXS-4-60	Strobe 60 Cd	-	115
GXS-4-110	Strobe 110 Cd	-	220
SHG24-15	Electronic Horn/Strobe 15 cd	108 (combined)	
SHG24-15/75-W	Electronic Horn/Strobe 15/75 cd	123 (combined)	
SHG24-15/75-C	Electronic Horn/Strobe 15/75 cd	145 (combined)	
SHG24-15/75-Z	Electronic Horn/Strobe 15/75 cd	160 (combined)	
SHG24-30	Electronic Horn/Strobe 30 cd	123 (combined)	
SHG24-30/75	Electronic Horn/Strobe 30/75 cd	172 (combined)	
SHG24-60	Electronic Horn/Strobe 60 cd	145 (combined)	
SHG24-110	Electronic Horn/Strobe 110 cd	250 (combined)	
ST24-15	Commander Strobe 15 cd	-	45
ST24-15/75	Commander Strobe 15/75 cd	-	57
ST24-30	Commander Strobe 30 cd	-	57
ST24-60	Commander Strobe 60 cd	-	84
ST24-75	Commander Strobe 75 cd	-	86
ST24-110	Commander Strobe 110 cd	-	110
HS24-15	Commander Horn/Strobe 15 cd	75 (combined)	
HS24-15/75	Commander Horn/Strobe 15/75 cd	87 (combined)	
HS24-30	Commander Horn/Strobe 30 cd	87 (combined)	
HS24-60	Commander Horn/Strobe 60 cd	114 (combined)	
HS24-75	Commander Horn/Strobe 75 cd	116 (combined)	
HS24-110	Commander Horn/Strobe 110 cd	140 (combined)	
Space Age			
SSU7620	Strobe	-	80
SSU7625	Strobe	-	130
SSU7630	Strobe	-	160
SSU7521	Horn/Strobe	93 (combined)	
SSU7526	Horn/Strobe	143 (combined)	
SSU7531	Horn/Strobe	173 (combined)	
System Sensor			
P2415 (R) (W)	Horn/Strobe	39	60

Model	Type	Input Current at 24 VDC (in mA)	
		Audible	Visual
P241575 (R) (W)	Horn/Strobe	39	64
P2475 (R) (W)	Horn/Strobe	39	159
P24110 (R) (W)	Horn/Strobe	39	191
P241575K	Horn/Strobe	39	64
P2475K	Horn/Strobe	39	159
P24110K	Horn/Strobe	39	191
P241575F	Horn/Strobe	39	64
S2415 (R) (W)	Strobe	-	60
S241575 (R) (W)	Strobe	-	64
S2475 (R) (W)	Strobe	-	159
S24110 (R) (W)	Strobe	-	191
S241575K	Strobe	-	64
S2475K	Strobe	-	159
S24110K	Strobe	-	191
S241575F	Strobe	-	64
MDL	Sync Module	15 (combined)	
MA12/24D	Electronic Sounder	59	-
SS24LO	Strobe	-	45
SS24LOC	Strobe	-	45
SS24M	Strobe	-	125
SS24MC	Strobe	-	125
SS24LOLA	Strobe	-	80
MASS24LO	Electronic Sounder/Strobe	59	45
MASS24LOC	Electronic Sounder/Strobe	59	45
MASS24LOLA	Electronic Sounder/Strobe	59	80
MASS24M	Electronic Sounder/Strobe	59	125
MASS24MC	Electronic Sounder/Strobe	59	125
PA400R (R) (W) (B)	Sounder	12	-
PA400RF (R) (W)	Sounder	12	-
PS24LO (R) (W) (B)	add on Strobe	-	25
SS2415ADA (R) (B)	Strobe	-	90
SS241575ADA (R) (B)	Strobe	-	120
SS2475ADA (R) (B)	Strobe	-	200
SS24110ADA (R) (B)	Strobe	-	245
MASS2415ADA (R) (B)	Horn/Strobe	59	90
MASS241575ADA (R) (B)	Horn/Strobe	59	120
MASS2475ADA (R) (B)	Horn/Strobe	59	200
MASS24110ADA (R) (B)	Horn/Strobe	59	245
SS2415ADAS	Strobe	-	125

Model	Type	Input Current at 24 VDC (in mA)	
		Audible	Visual
SS241575ADAS	Strobe	-	180
MASS2415ADAS	Horn/Strobe	59	125
MASS241575ADAS	Horn/Strobe	59	180
RP2415ADA	Strobe	-	90
RP241575ADA	Strobe	-	120
RP2475ADA	Strobe	-	200
RP24110ADA	Strobe	-	245

7.5 UL Listed Analog Addressable Devices

The following Listed analog addressable smoke detectors, detector bases, monitor modules, control modules and fault isolator modules are compatible with the MR-2900 Control Panel using the MR-2909 and/or MR-2919 Addressable Input Circuit Modules. Up to 99 detectors and 99 monitor/control modules may be connected to each addressable communications circuit. Refer to the installation instructions which accompany each device for details of installation wiring and proper application.

Manufacturer	Model	Type
Secutron	MRI-1251B	Ionization type smoke detector
	MRI-2251B	Photoelectric type smoke detector
	MRI-2251TB	Photoelectric type smoke detector w/ thermal element
	MRI-2251TMB	Acclimate Photoelectric type smoke Detector w/ thermal element
	MRI-5251B	Thermostat
	MRI-5251RB	Thermostat w/ Rate of Rise
	MRI-5251H	High Temperature Thermostat
	MRI-M500M	Monitor module, Classes A/B initiating
	MRI-M501M	Mini Monitor module, "Class B" initiating
	MRI-M502M	Monitor Module for 2-wire smoke detectors
	MRI-M500R	Control module
	MRI-M500S	Control module
	MRI-M500X	Fault isolator module

Manufacturer	Model	Type
System Sensor	1251	Ionization type smoke detector
	1251B	Ionization type smoke detector
	2251	Photoelectric type smoke detector
	2251B	Photoelectric type smoke detector
	2251T	Photoelectric type smoke detector w/ thermal element
	2251TB	Photoelectric type smoke detector w/ thermal element
	2251TM	Acclimate Photo-Thermal Detector
	2251TMB	Acclimate Photo-Thermal Detector
	7251	Pinnacle™ Intelligent Laser Smoke Sensor
	5251P	Thermal detector
	5251B	Thermal detector
	5251RP	Thermal detector w/ rate of rise
	5251RB	Thermal detector w/ rate of rise
	5251H	High Temperature Thermal detector
	IM-10	10 Input Monitor Module
	CR-6	6 Relay Control Module
	SC-6	6 Supervised Control Module
	CZ-6	6 Zone Conventional Interface Module
	M500DM	Dual Input Monitor Module
	M500M	Monitor module, Classes A/B initiating
	M501M	Mini Monitor module, Class B initiating
	M502M	Monitor Module for 2- wire smoke detectors Classes A/B initiating
	M500S	Control module
	M500R	Relay Module
	M500X	Fault isolator module

7.6 UL Listed Compatible Door Holder/Releasers

The following listed door holders are compatible with the MR-2900 and MR-2400 door holder/releaser circuits:

Manufacturer	Model	Type	Input Current at 24 VDC
Harrington	1501-G1	Single Door, Floor Mount	70 mA
	1502-G1	Double Door, Floor Mount	140 mA
	1504-G1	Flush Wall Mount, Large Catch Plate	70mA
	1505-G1	Flush Wall Mount	70 mA
	1508-G1	Surface Wall Mount	70 mA
	1509-G1	Completely Flush Wall Mount	70 mA

8.0 Appendix D: Interconnection to Other Equipment

8.1 Radionics 2071C and 2071AC

The wiring between the MR-2900 and the Radionics 2071C and 2071AC Dialers is as shown in the following diagram:

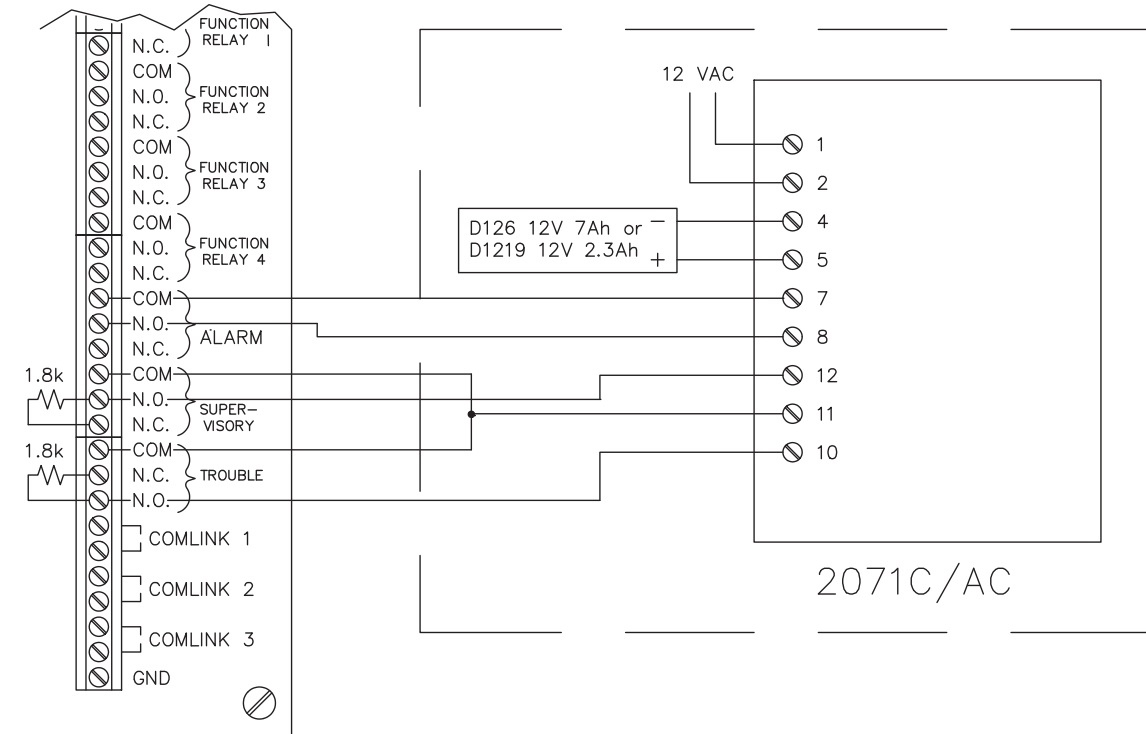

Figure 30: MR-2900 and Radionics 2071C/2071AC Wiring

An addressable module may be substituted for the alarm relay as follows:

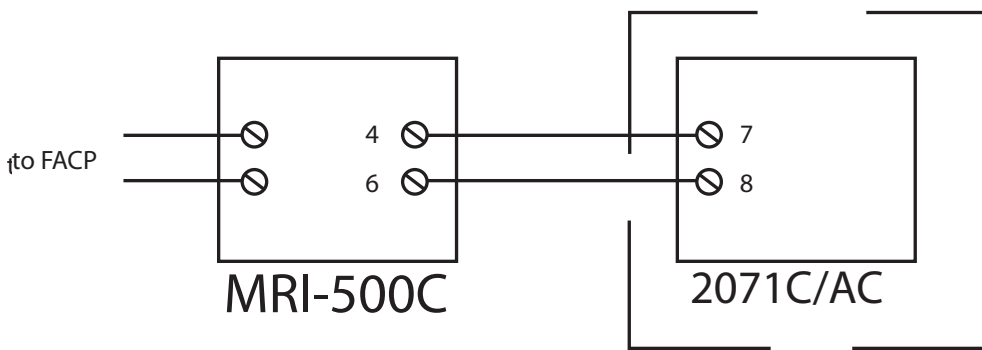

Figure 31: MR-2900 and Radionics 2071C/2071AC Wiring with addressable module substituted for alarm relay

Trouble and supervisory contacts must be connected to the panel.



Note: The Radionics 2071C and 2071AC are separately listed equipment. Refer to the installation and wiring instructions provided with the unit.

8.2 Silent Knight 5104

The wiring between the MR-2900 and the Silent Knight 5104 Dialer is as shown in the following diagram:

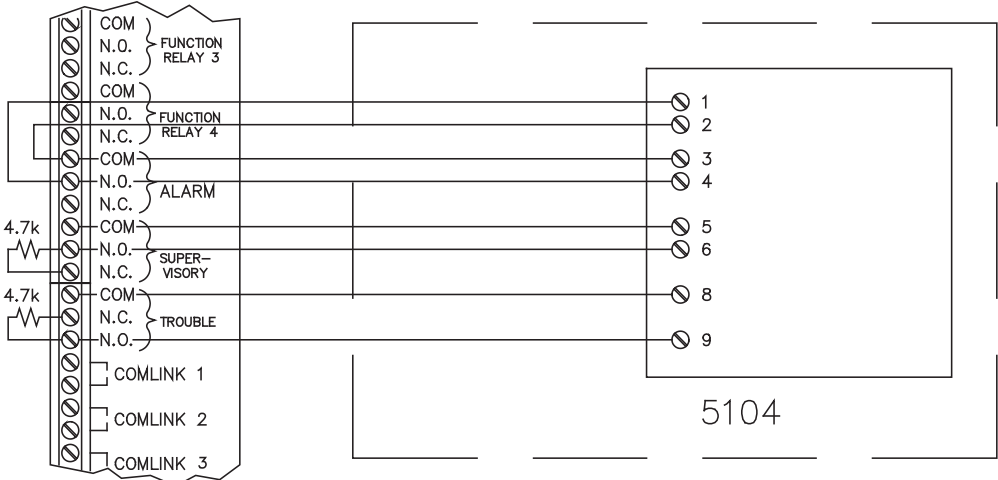

Figure 32: MR-2900 and Silent Knight 5104 Dialer Wiring

An addressable module may be substituted for the common alarm relay as follows:

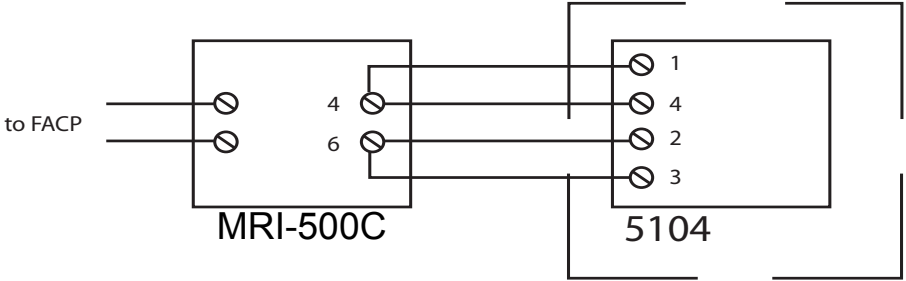

Figure 33: MR-2900 and Silent Knight 5104 Dialer Wiring with addressable module substituted for common alarm relay

An addressable module may be substituted for the common supervisory relay as follows:

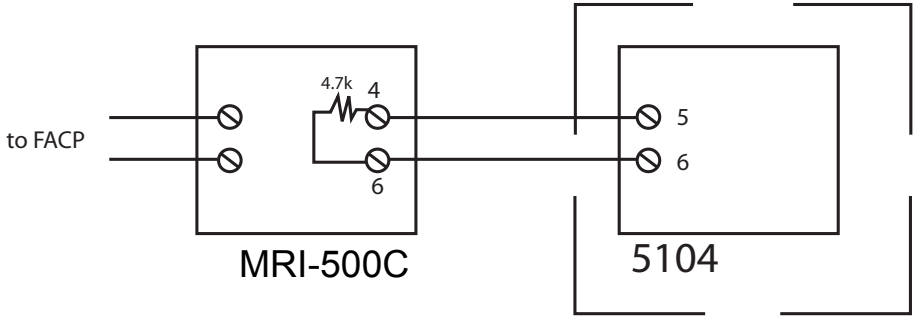

Figure 34: MR-2900 and Silent Knight 5104 Dialer Wiring with addressable module substituted for common supervisory relay

Trouble contacts must be connected to the panel.



Note: The Silent Knight 5104 is separately listed equipment. Refer to the installation and wiring instructions provided with the unit.

8.3 CTM City Tie Module

The CTM is designed to interface between a control panel and a local city tie box. The interface from the control panel is via a 24VDC signal circuit. This module is intended for connection to the control unit at the protected premises.

Ratings:

City Tie Module

- Operating Voltage 24 VDC
- Standby Current 2 mA
- Alarm Current 1.5 A (less than 10 milliseconds) for Model DC-2A Master Box
- UL listed File S3610

City Tie Box

- Series type Coil Resistance 14.5 ohms

The CTM is wired as shown below.

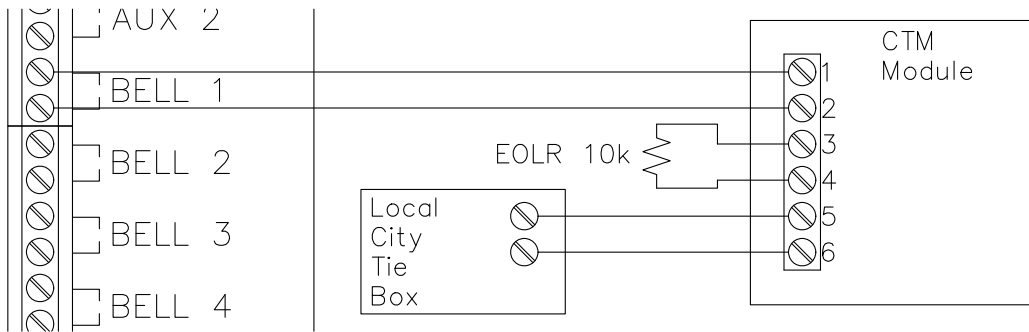

Figure 35: CTM City Tie Module Wiring



Note:

- The CTM is separately listed equipment. Refer to the installation and wiring instructions provided with the unit.
- When connecting the CTM module to any of the bell (NAC) circuits, that circuit(s) must be programmed as a strobe circuit

8.4 Keltron 3158 TTM

The Keltron 3158 TTM and the MR-2900 are wired together as shown below:

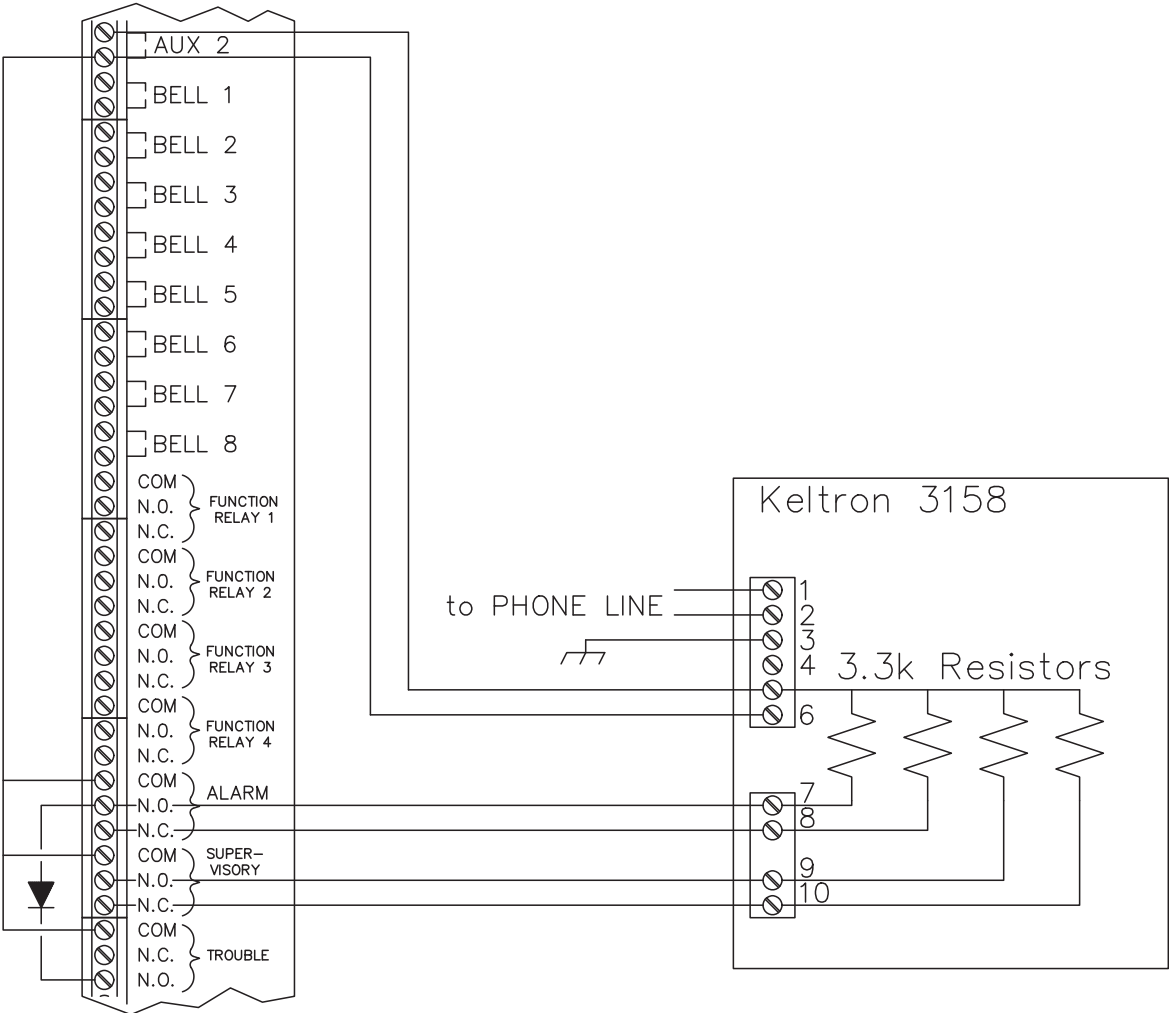

Figure 36: MR-2900 and Keltron 3158 TTM Wiring

Addressable control modules cannot be used with the Keltron 3158 TTM.



Note: The Keltron 3158 TTM is separately listed equipment. Refer to the installation and wiring instructions provided with the unit.

9.0 Warranty & Warning Information

9.1 Warning Please Read Carefully

Note to End Users: This equipment is subject to terms and conditions of sale as follows:

Note to Installers

This warning contains vital information. As the only individual in contact with system users, it is your responsibility to bring each item in this warning to the attention of the users of this system. Failure to properly inform system end-users of the circumstances in which the system might fail may result in over-reliance upon the system. As a result, it is imperative that you properly inform each customer for whom you install the system of the possible forms of failure.

System Failures

This system has been carefully designed to be as effective as possible. There are circumstances, such as fire or other types of emergencies where it may not provide protection. Alarm systems of any type may be compromised deliberately or may fail to operate as expected for a variety of reasons. Some reasons for system failure include:

•Inadequate Installation

A Fire Alarm system must be installed in accordance with all the applicable codes and standards in order to provide adequate protection. An inspection and approval of the initial installation, or, after any changes to the system, must be conducted by the Local Authority Having Jurisdiction. Such inspections ensure installation has been carried out properly.

•Power Failure

Control units, smoke detectors and many other connected devices require an adequate power supply for proper operation. If the system or any device connected to the system operates from batteries, it is possible for the batteries to fail. Even if the batteries have not failed, they must be fully charged, in good condition and installed correctly. If a device operates only by AC power, any interruption, however brief, will render that device inoperative while it does not have power. Power interruptions of any length are often accompanied by voltage fluctuations which may damage electronic equipment such as a fire alarm system. After a power interruption has occurred, immediately conduct a complete system test to ensure that the system operates as intended.

•Failure of Replaceable Batteries

Systems with wireless transmitters have been designed to provide several years of battery life under normal conditions. The expected battery life is a function of the device environment, usage and type. Ambient conditions such as high humidity, high or low temperatures, or large temperature fluctuations may reduce the expected battery life. While each transmitting device has a low battery monitor which identifies when the batteries need to be replaced, this monitor may fail to operate as expected. Regular testing and maintenance will keep the system in good operating condition.

•Compromise of Radio Frequency (Wireless) Devices

Signals may not reach the receiver under all circumstances which could include metal objects placed on or near the radio path or deliberate jamming or other inadvertent radio signal interference.

•System Users

A user may not be able to operate a panic or emergency switch possibly due to permanent or temporary physical disability, inability to reach the device in time, or unfamiliarity with the correct operation. It is important that all system users be trained in the correct operation of the alarm system and that they know how to respond when the system indicates an alarm.

•Automatic Alarm Initiating Devices

Smoke detectors, heat detectors and other alarm initiating devices that are a part of this system may not properly detect a fire condition or signal the control panel to alert occupants of a fire condition for a number of reasons, such as: the smoke detectors or heat detector may have been improperly installed or positioned; smoke or heat may not be able to reach the alarm initiating device, such as when the fire is in a chimney, walls or roofs, or on the other side of closed doors; and, smoke and heat detectors may not detect smoke or heat from fires on another level of the residence or building.

•Software

Most Secutron products contain software. With respect to those products, Secutron does not warranty that the operation of the software will be uninterrupted or error-free or that the software will meet any other standard of performance, or that the functions or performance of the software will meet the user's requirements. Secutron shall not be liable for any delays,

breakdowns, interruptions, loss, destruction, alteration or other problems in the use of a product arising out of, or caused by, the software.

Every fire is different in the amount and rate at which smoke and heat are generated. Smoke detectors cannot sense all types of fires equally well. Smoke detectors may not provide timely warning of fires caused by carelessness or safety hazards such as smoking in bed, violent explosions, escaping gas, improper storage of flammable materials, overloaded electrical circuits, children playing with matches or arson.

Even if the smoke detector or heat detector operates as intended, there may be circumstances when there is insufficient warning to allow all occupants to escape in time to avoid injury or death.

- *Alarm Notification Appliances*

Alarm Notification Appliances such as sirens, bells, horns, or strobes may not warn people or waken someone sleeping if there is an intervening wall or door. If notification appliances are located on a different level of the residence or premise, then it is less likely that the occupants will be alerted or awakened. Audible notification appliances may be interfered with by other noise sources such as stereos, radios, televisions, air conditioners or other appliances, or passing traffic. Audible notification appliances, however loud, may not be heard by a hearing-impaired person.

- *Telephone Lines*

If telephone lines are used to transmit alarms, they may be out of service or busy for certain periods of time. Also the telephone lines may be compromised by such things as criminal tampering, local construction, storms or earthquakes.

- *Insufficient Time*

There may be circumstances when the system will operate as intended, yet the occupants will not be protected from the emergency due to their inability to respond to the warnings in a timely manner. If the system is monitored, the response may not occur in time enough to protect the occupants or their belongings.

- *Component Failure*

Although every effort has been made to make this system as reliable as possible, the system may fail to function as intended due to the failure of a component.

- *Inadequate Testing*

Most problems that would prevent an alarm system from operating as intended can be discovered by regular testing and maintenance. The complete system should be tested as required by national standards and the Local Authority Having Jurisdiction and immediately after a fire, storm, earthquake, accident, or any kind of construction activity inside or outside the premises. The testing should include all sensing devices, keypads, consoles, alarm indicating devices and any other operational devices that are part of the system.

- *Security and Insurance*

Regardless of its capabilities, an alarm system is not a substitute for property or life insurance. An alarm system also is not a substitute for property owners, renters, or other occupants to act prudently to prevent or minimize the harmful effects of an emergency situation.

IMPORTANT NOTE: End-users of the system must take care to ensure that the system, batteries, telephone lines, etc. are tested and examined on a regular basis to ensure the minimization of system failure.

9.2 Limited Warranty

Secutron Inc. warrants the original purchaser that for a period of two years from the date of manufacture, the product shall be free of defects in materials and workmanship under normal use. During the warranty period, Secutron Inc. shall, at its option, repair or replace any defective product upon return of the product to its factory, at no charge for labor and materials. Any replacement and/or repaired parts are warranted for the remainder of the original warranty or ninety (90) days, whichever is longer. The original owner must promptly notify Secutron Inc. in writing that there is defect in material or workmanship, such written notice to be received in all events prior to expiration of the warranty period.

International Warranty

The warranty for international customers is the same as for any customer within Canada and the United States, with the exception that Secutron Inc. shall not be responsible for any customs fees, taxes, or VAT that may be due.

Conditions to Void Warranty

This warranty applies only to defects in parts and workmanship relating to normal use. It does not cover:

- damage incurred in shipping or handling;
- damage caused by disaster such as fire, flood, wind, earthquake or lightning;
- damage due to causes beyond the control of Secutron Inc. such as excessive voltage, mechanical shock or
- water damage;
- damage caused by unauthorized attachment, alterations, modifications or foreign objects;
- damage caused by peripherals (unless such peripherals were supplied by Secutron Inc.);
- defects caused by failure to provide a suitable installation environment for the products;
- damage caused by use of the products for purposes other than those for which it was designed;
- damage from improper maintenance;
- damage arising out of any other abuse, mishandling or improper application of the products.

9.3 Warranty Procedure

To obtain service under this warranty, please return the item(s) in question to the point of purchase. All authorized distributors and dealers have a warranty program. Anyone returning goods to Secutron Inc. must first obtain an authorization number. Secutron Inc. will not accept any shipment whatsoever for which prior authorization has not been obtained. NOTE: Unless specific pre-authorization in writing is obtained from Secutron management, no credits will be issued for custom fabricated products or parts or for complete fire alarm system. Secutron will at its sole option, repair or replace parts under warranty. Advance replacements for such items must be purchased.

Note: Secutron Inc.'s liability for failure to repair the product under this warranty after a reasonable number of attempts will be limited to a replacement of the product, as the exclusive remedy for breach of warranty.

9.4 Disclaimer of Warranties

This warranty contains the entire warranty and shall be in lieu of any and all other warranties, whether expressed or implied (including all implied warranties of merchantability or fitness for a particular purpose) And of all other obligations or liabilities on the part of Secutron Inc. neither assumes nor authorizes any other person purporting to act on its behalf to modify or to change this warranty, nor to assume for it any other warranty or liability concerning this product.

This disclaimer of warranties and limited warranty are governed by the laws of the province of Ontario, Canada.

9.5 Out of Warranty Repairs

Secutron Inc. will at its option repair or replace out-of-warranty products which are returned to its factory according to the following conditions. Anyone returning goods to Secutron Inc. must first obtain an authorization number. Secutron Inc. will not accept any shipment whatsoever for which prior authorization has not been obtained.

Products which Secutron Inc. determines to be repairable will be repaired and returned. A set fee which Secutron Inc. has predetermined and which may be revised from time to time, will be charged for each unit repaired.

Products which Secutron Inc. determines not to be repairable will be replaced by the nearest equivalent product available at that time. The current market price of the replacement product will be charged for each replacement unit.



© 2009 Secutron, Inc.

No part of this publication may be reproduced, transmitted, transcribed, stored in a retrieval system, or translated into any language or computer language, in any form by any means electronic, magnetic, optical, chemical, manual, or otherwise without the prior consent of Secutron.

Canada
25 Interchange Way
Vaughan, ON L4K 5W3
Tel: (888) SECUTRON
(888) 732-8876
Fax: (905) 660-4113

U.S.A
4575 Witmer Industrial Estates
Niagara Falls, New York 14305
Tel: (888) SECUTRON
(888) 732-8876
Fax: (905) 660-4113